

# SonicaidFM800

## *Reference Manual*

© Huntleigh Healthcare Ltd 2005  
All rights reserved  
329000-5  
September 2007

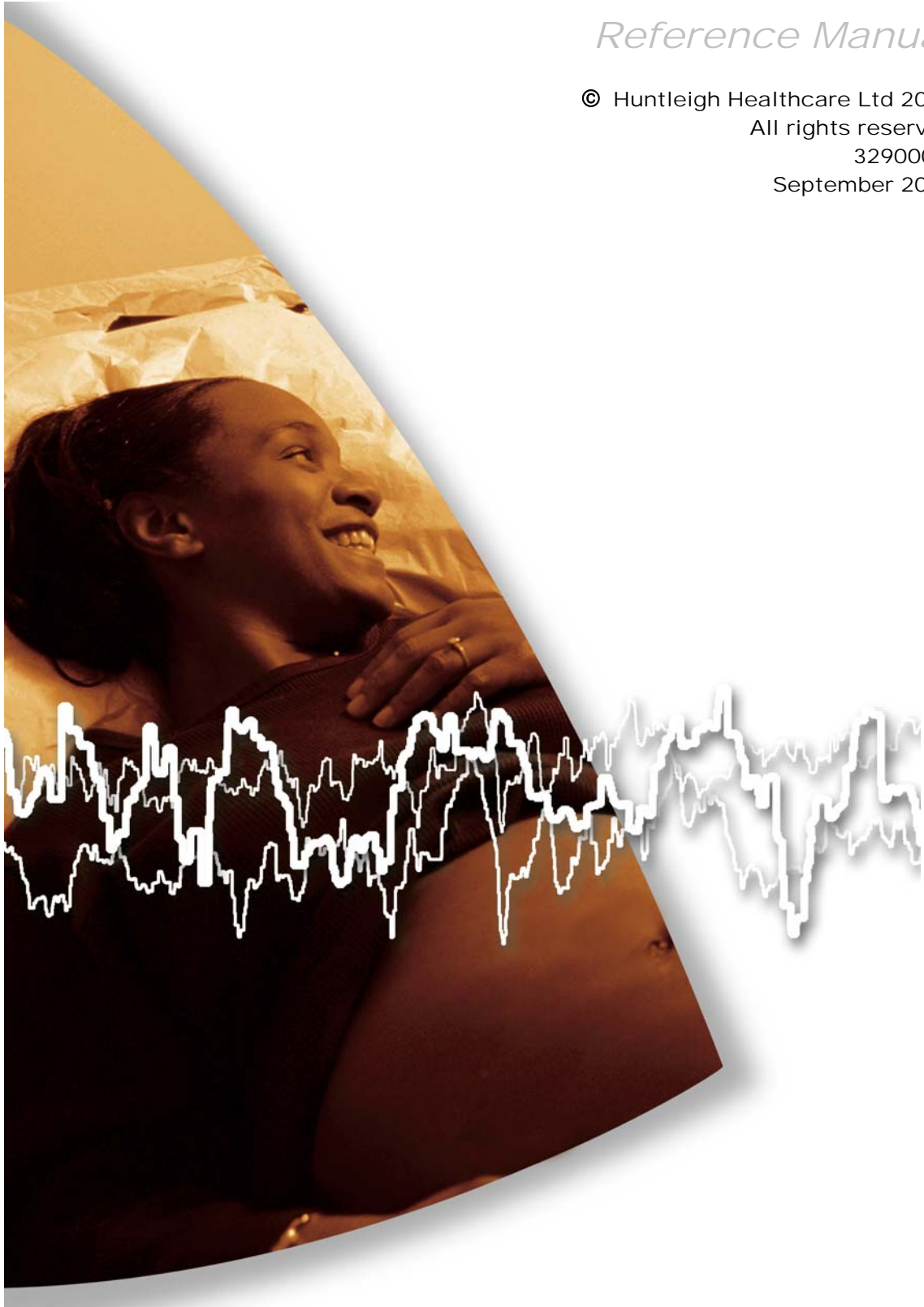



The Sonicaid™ FM800 is in conformity with the Medical Device Directive (93/42/EEC) and has been subject to the conformity assurance procedures laid down in the Council Directive.

# Contents

Contents .....	3
Standards compliance.....	7
Indications for use .....	8
System Installation .....	9
Calibration .....	9
Multiple Portable Socket Outlets .....	10
Electromagnetic compatibility.....	11
Trademarks .....	12
Sensors .....	12
Addresses .....	13
1 Introduction.....	14
1.1 The FM800 series .....	14
1.2 Main unit: front panel .....	16
1.3 Connection sockets for transducers .....	17
1.4 Main unit: rear connectors .....	18
1.5 Connector module .....	19
1.6 Event marker connection .....	20
1.7 The FM800 display .....	20
1.8 Transducers and cables .....	21
1.9 FM800 trolley or wall mounting.....	22
2 FM800 Controls and Display.....	23
2.1 Controls and on/off indicator.....	23
2.2 FM800 main screen .....	24
2.3 Software control buttons .....	25
2.4 Audio controls .....	26
2.5 Printer controls.....	27
2.6 Loading printer paper.....	28
3 Setup .....	29
3.1 Overview .....	29
3.2 Current alarms .....	29
3.3 Default alarms.....	30
3.4 System settings.....	30
3.5 Analysis.....	30
3.6 Time and date .....	30
3.7 Patient details .....	31
3.8 Timer.....	32
3.9 Actogram settings .....	33

4	System Settings and Default Alarms .....	34
4.1	Overview .....	34
4.2	Changing the default alarms.....	35
4.3	Printer setup.....	35
4.4	Audio/graphic settings .....	37
4.5	International settings.....	38
4.6	Serial interface.....	39
5	Monitoring Fetal Parameters.....	40
5.1	Preliminary .....	40
5.2	Audio signal .....	40
5.3	Ultrasound monitoring.....	41
5.4	The FHR confidence indicator .....	43
5.5	False recording of low baseline FHR.....	43
5.6	Ultrasound for twins .....	44
5.7	Fetal ECG (using a scalp electrode).....	45
5.8	Accidentally recording the wrong signal .....	50
6	Monitoring Maternal Parameters .....	51
6.1	Contractions (using Toco transducer) .....	51
6.2	Contractions (using IUP transducer) .....	52
6.3	Maternal ECG .....	52
6.4	Maternal Blood Pressure .....	56
6.5	Maternal Oximetry .....	58
6.6	Maternal temperature .....	61
7	Events and Alarms .....	62
7.1	What is meant by an alarm? .....	62
7.2	What do you see and hear?.....	62
7.3	Responding to alarms.....	64
7.4	Controlling alarms.....	65
7.5	Recording fetal movements .....	65
7.6	Actogram.....	66
7.7	Recording clinical events (EasiNotes).....	68
8	Setting Alarm Thresholds.....	69
8.1	Default alarm thresholds.....	69
8.2	FHR thresholds (Ultrasound and FECG).....	70
8.3	Maternal blood pressure thresholds .....	73
8.4	MECG thresholds .....	73
8.5	Maternal oximetry threshold .....	74
8.6	Temperature thresholds.....	74
9	SonicaidTrend Intrapartum Analysis.....	75
9.1	Introduction .....	75
9.2	SonicaidTrend analysis.....	76
9.3	Using SonicaidTrend analysis .....	77
9.4	SonicaidTrend analysis results.....	78
9.5	Viewing trend data .....	78

10	SonicaidCare Antepartum Analysis .....	79
10.1	Intended use .....	79
10.2	Overview .....	79
10.3	The Dawes/Redman criteria .....	80
10.4	Care analysis .....	80
10.5	Using SonicaidCare analysis .....	81
10.6	SonicaidCare analysis report .....	82
11	Using FM800 with a PC System .....	85
11.1	Using FM800 with FetalCare or System8002 .....	85
11.2	Using FM800 with Sonicaid Axis .....	86
11.3	Using FM800 with Sonicaid Centrale, Philips TraceVue™ or GMT Argus .....	86
12	Telemetry .....	88
12.1	Connecting the telemetry unit .....	88
12.2	Using the telemetry unit .....	88
13	Troubleshooting .....	89
13.1	FHR .....	89
13.2	Oximetry .....	89
13.3	Fetal event marker .....	89
13.4	Maternal blood pressure error codes .....	90
13.5	Printing .....	90
13.6	What to do next? .....	91
14	Cleaning and Maintenance .....	92
14.1	The FM800 main unit .....	92
14.2	Transducers: NBP cuff, maternal oximetry sensor, temperature probe .....	92
14.3	Transducers and leads: Ultrasound, FECG, MEKG, internal Toco and external Toco .....	93
14.4	User maintenance .....	94
14.5	Technical maintenance .....	95
14.6	Corrective maintenance .....	96
14.7	Servicing .....	96
14.8	Accessories, consumables and spares .....	97
15	Specifications .....	99
15.1	Physical and environmental .....	99
15.2	AC supply voltage and fuse values .....	99
15.3	Transducers .....	100
15.4	Controls .....	104
15.5	Printer .....	104
15.6	Connections .....	105
15.7	Display .....	106
15.8	Safety .....	107
15.9	Ultrasound safety considerations .....	108
16	Appendix 1: Service and Warranty .....	110
17	Appendix 2: External Connections .....	111

*Sonicaid FM800 Series Reference Manual*

18	Appendix 3: Transducer Problems .....	113
19	Appendix 4: Getting Started with T800 .....	115

## Standards compliance

SonicaidFM800 complies with:

EN60601-1, 1990

Medical Electrical Equipment Part 1  
General Requirements for Safety

EN60601-1-1, 1993  
[collateral standard]

Safety Requirements for Medical  
Electrical Systems



Patient safety

WARNING: DO NOT TOUCH LIVE PARTS OF ANY EQUIPMENT (eg COM  
PORT CONNECTOR PINS ON A PC) AND THE PATIENT AT THE SAME TIME.

CE Mark



Denotes conformity with the European Council  
Directive 93/42/EEC concerning medical devices.

Classification symbol



Indicates Type CF applied part.

## Indications for use

Huntleigh Healthcare Ltd Sonicaid FM800 series fetal monitors are indicated for use in monitoring fetal and maternal vital signs during the intrapartum and antepartum periods.

Sonicaid FM820 provides comprehensive fetal monitoring facilities, offering twin ultrasound fetal heart rate, separate fetal and maternal ECG channels, external and internal uterine activity monitoring and maternally sensed fetal movements.

Sonicaid FM830 provides additional maternal monitoring with facilities for simultaneous monitoring of maternal pulse oximetry, blood pressure and temperature without the need for additional stand-alone devices.

### Notes

US Federal Law restricts this device to sale on or by the order of a physician.

Sonicaid Care analysis and Sonicaid Trend analysis are not approved for sale in the USA and Canada.

Warning: do not use the maternal oximetry sensors during magnetic resonance imaging (MRI) scanning. Induced current could cause burns. The oximeter may affect the MRI image, and the MRI unit may affect the accuracy of oximetry measurements.



## System Installation

These requirements must be met when you connect an FM800 fetal monitor to any of the following pieces of equipment:

- a central review and archiving system
  - a PC
  - a VGA monitor:
- 1 Non-medical equipment must comply with the relevant IEC or ISO safety standard. For Information Technology equipment, this standard is IEC950/EN60950.
  - 2 Medical equipment must comply with IEC601-1/EN60601-1.
  - 3 The configured system must comply with the system standard IEC601-1-1/EN60601-1-1.
  - 4 If non-medical equipment (eg the PC or printer) with enclosure leakage currents greater than those allowed by IEC601-1/EN60601-1 is to be used in the patient environment (within 1.5m of the patient), you must bring the enclosure leakage currents within the limits laid down by IEC601-1/EN60601-1. This may be done by using an isolating transformer such as the one supplied by Huntleigh Healthcare Ltd.
  - 5 Anybody who connects additional equipment to signal input or signal output parts of the system is configuring a medical system, and is therefore responsible for ensuring that the system complies with IEC601-1-1/EN60601-1-1. If you are in any doubt whether your system does comply, consult the technical service department of your local Huntleigh Healthcare Ltd representative.

The connection of extra equipment to the patient or FM800 could lead to the summation of leakage currents. In such circumstances the user must ensure that safe leakage currents are not exceeded.

## Calibration

The NBP module should be calibrated every 12 months. See Section 14.5. Apart from this, there is no special procedure for calibrating FM800.

## Multiple Portable Socket Outlets (including isolation transformers)

Note: an isolation transformer is a particular kind of multiple socket outlet.

It is not recommended to power a medical system from a multiple portable socket outlet which is not supplied from an isolation transformer (IEC601-1-1/EN60601-1-1 Amendment 1).

If such an outlet is in use, it should comply with the requirements of Annexe EEE.2 of IEC601-1-1/EN60601-1-1 Amendment 1.

### WARNINGS

- 1 Do not exceed the power rating for the multiple portable socket outlet.
- 2 Do not place multiple portable socket-outlets on the floor. This is to protect against mechanical damage and the ingress of liquids.
- 3 Multiple portable socket-outlets supplied with the system must not be used for powering equipment which does not form part of the system. This is to prevent increased leakage currents, and overload of the multiple portable socket outlet.
- 4 If the system has been specified for use with an isolation transformer, do not connect any non-medical electrical equipment which forms part of the system directly to the wall outlet. This is to prevent excessive leakage currents.
- 5 Non-medical electrical equipment situated in the patient environment (within 1.5 metres of the patient) must be powered via an isolation transformer, to limit leakage current.

For more information on the connection and use of isolation transformers, consult the user manual for the medical system you have purchased.

## Electromagnetic compatibility

Make sure the environment in which FM800 is installed is not subject to strong sources of electromagnetic interference (eg radio transmitters, mobile phones).

This equipment generates and uses radio frequency energy. If not installed and used properly, in strict accordance with the manufacturer's instructions, it may cause or be subject to interference. Type-tested in a fully configured system, it has been found to comply with IEC601-1-2/EN60601-1-2, the standard intended to provide reasonable protection against such interference. Whether the equipment causes interference may be determined by turning the equipment off and on. If it does cause or is affected by interference, one or more of the following measures may correct the interference:

- Reorienting the equipment
- Relocating the equipment with respect to the source of interference
- Moving the equipment away from the device with which it is interfering
- Plugging the equipment into a different outlet so that the devices are on different branch circuits

Adding accessories or components to a system, or modifying a medical device or system, may degrade the immunity performance. Consult qualified personnel before making changes to the system configuration.

## Trademarks

Sonicaid™ is a registered trademark of Huntleigh Healthcare Ltd.

TempHearts™ is a registered trademark of YSI Corporation.

TraceVue™ is a registered trademark of Philips.

Safelinc™ is a registered trademark of Tyco.

## Sensors

Care and disposal

Re-usable probes and sensors: store and maintain in accordance with the instructions supplied by the manufacturer. Probes and sensors which do not work, or which are no longer required, should be disposed of in accordance with local regulations.

Single-use probes and sensors: dispose of these after use in accordance with local regulations.

Oximeter sensors

The use of original oximetry sensors supplied by the manufacturer is strongly recommended.

## Addresses

UK  
Huntleigh Healthcare Ltd  
35 Portmanmoor Road, Cardiff.  
CF24 5HN. UK.  
Tel: +44 (0) 2920 485885  
Fax: +44 (0) 2920492520  
E-mail: [sales@huntleigh-diagnostics.co.uk](mailto:sales@huntleigh-diagnostics.co.uk)  
Web page [www.huntleigh-healthcare.com](http://www.huntleigh-healthcare.com)

# 1 Introduction

## 1.1 The FM800 series

FM800 series monitors are designed for antepartum and intrapartum monitoring. There are four monitors in the series:

- FM820**            Standard monitor  
Comprehensive monitoring using twin ultrasound and separate ECG channels. Gives great flexibility in monitoring multiple pregnancies.  
For example:  
    Twin ultrasound and maternal ECG  
    Ultrasound, fetal ECG and maternal ECG  
    Twin ultrasound plus fetal ECG  
FM820 also provides external and internal monitoring of uterine activity, and maternally sensed fetal movements
- FM830**            Standard monitor **plus**  
    Maternal pulse oximetry  
    Maternal non-invasive blood pressure  
    Maternal temperature

This reference manual covers the whole FM800 range and may describe some facilities not available in the FM800 you have bought. Note that FM820 can be upgraded to FM830.

FM820: standard features

The following features are available on all monitors in the FM800 range:

- Alarms
- Annotation
- Audio
- Display autodim
- Direct FEKG via scalp electrode
- Fetal event marker
- Interface to Rimkus telemetry
- Interface to Sonicaid Axis
- Interface to Sonicaid System 8002 / Fetalcare
- Interface to Sonicaid Centrale and other CMS packages
- IUP: internal uterine activity
- Maternal Heart Rate via ECG (MECG lead supplied as option)
- Toco: external uterine activity
- Ultrasound 1: 1.5MHz
- Ultrasound 2: 2.0MHz
- Thermal printer
- SonicaidCare (antepartum) analysis\*
- SonicaidTrend (intrapartum) analysis\*

*\* Not approved for sale in USA and Canada.*

## 1.2 Main unit: front panel

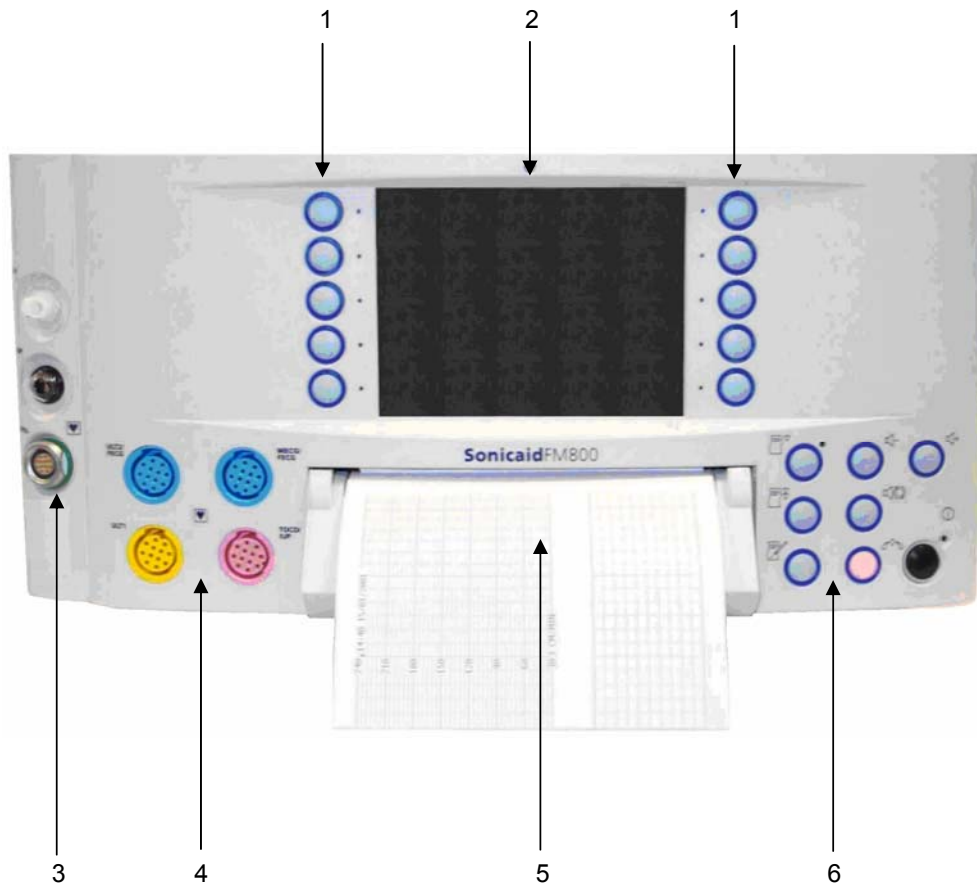

- 1 Software control buttons
- 2 Display: see chapter 2
- 3 Connector module for oximetry, blood pressure and temperature
- 4 Connection sockets for transducers
- 5 Printer drawer
- 6 Controls and on/off indicators: see chapter 2.



### 1.3 Connection sockets for transducers

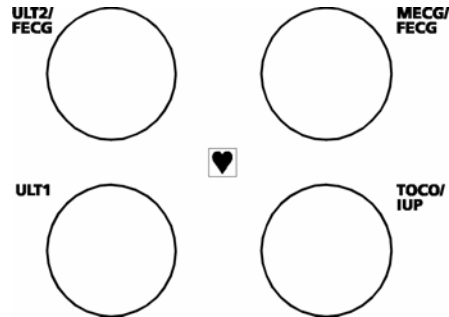

ULT1	1.5 MHz Ultrasound transducer, yellow
ULT2/FECEG	2.0 MHz Ultrasound transducer, blue OR Fetal ECG electrode, blue (connected via leg plate)
MECG	Maternal ECG transducer, blue
TOCO/IUP	Toco contractions transducer, pink OR IUP catheter-transducer, pink







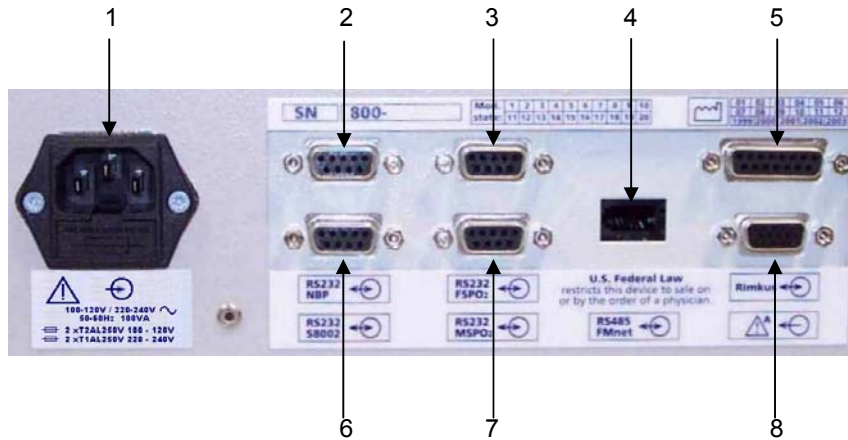

Classification symbol



This symbol indicates Type CF applied part.

### 1.4 Main unit: rear connectors



- 1 Input socket for the AC mains supply 
- 2 RS232 connector for external NBP, 9-way D-type socket (reserved for future use) 
- 3 RS232 connector for external FspO<sub>2</sub>, 9-way D-type socket (reserved for future use) 
- 4\* RS485 Interface for Axis (1.5kV DC isolation) (not used) 
- 5\* Connector for Rimkus Telemetry\*\* 15-way D-type socket 
- 6 RS232 connector for Sonicaid Centrale, FetalCare, Philips TraceVue™, GMT Argus\*\* 9-way D-type socket NB this connector will also accept an RS232 to RS422 adaptor lead for connection to Philips TraceVue™ 
- 7 RS232 connector for external MSpO<sub>2</sub> 9-way D-type socket (reserved for future use) 
- 8 VGA connector, 15-way compact D-type socket See notes on page 9 

This symbol means Date of Manufacture



\* For pin connections, see Appendix 2.

\*\* Not approved for use with Sonicaid FM800 in the USA or Canada.

## 1.5 Connector module

FM830 offers additional features via a connector module.

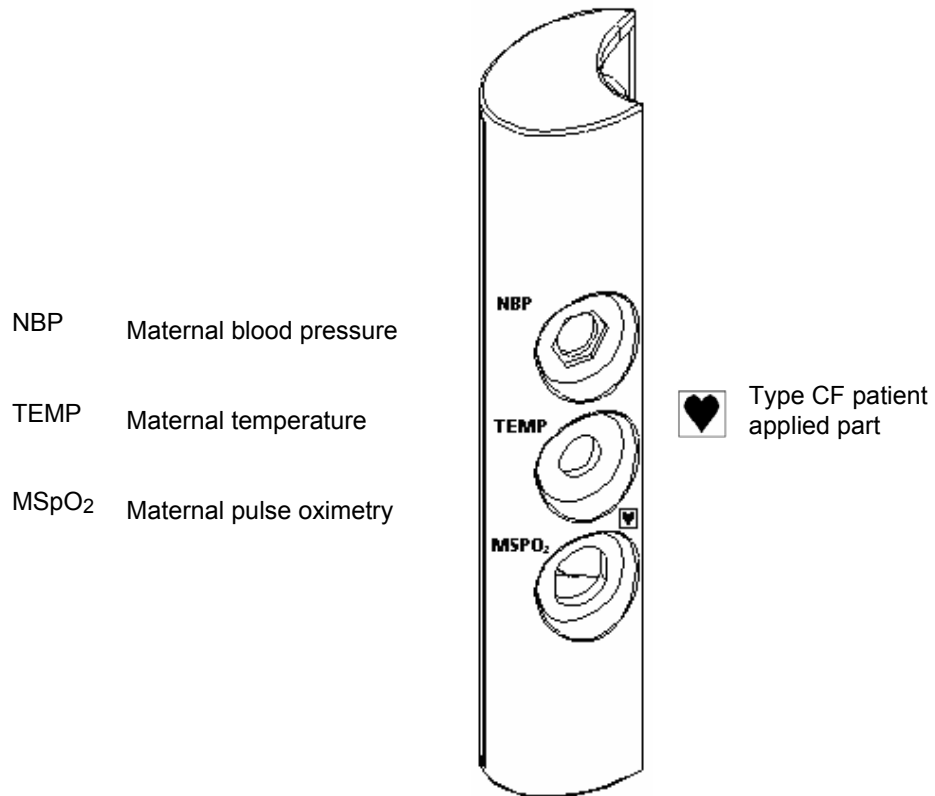

### FM830

The connector module has connectors for maternal blood pressure, maternal oximetry and maternal temperature. The fetal oximetry connector is blanked off.

## 1.6 Event marker connection

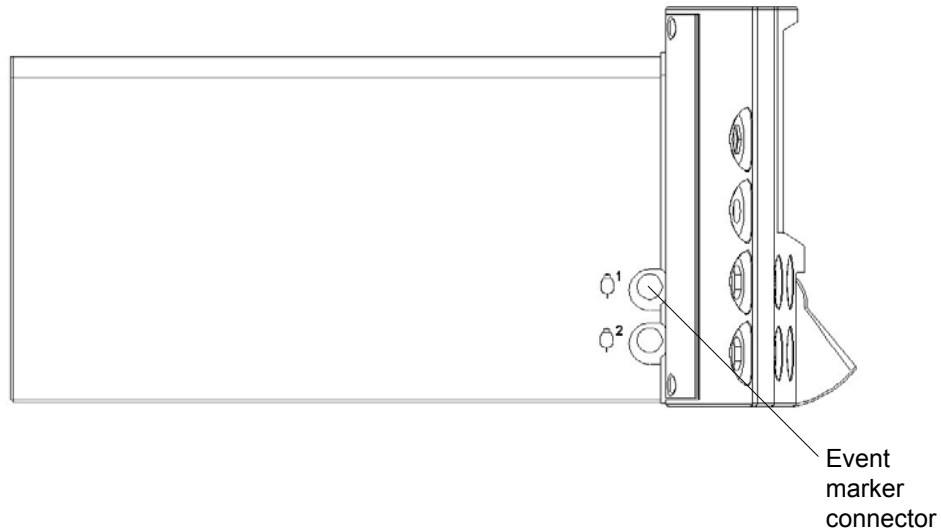

## 1.7 The FM800 display

The FM800's high-performance display combines superior visual performance with environmental ruggedness, making it suitable for a wide range of environments.

The principal benefits of the FM800 display are:

- High brightness and contrast
- Wide viewing angle:  $>160^\circ$
- Display auto-dims when FM800 is used in subdued lighting
- Extremely rugged and durable
- Reliable, long operating life

Note: as with other light-emitting displays, displaying fixed patterns on the screen can cause a limited degree of burn-in. Some slight variation in luminance, as a result of this, is perfectly normal.

## 1.8 Transducers and cables

### Supplied with all units

Ultrasound transducers	Yellow, 1.5MHz (primary) Blue, 2.0MHz (secondary)
Fetal ECG lead	Blue
Toco transducer	Pink
Transducer belts	3
Transducer buckles	3
FECG lead leg belts/electrode pads	2
Fetal movement event marker	1
Mains lead	1

### Supplied with FM830

NBP air line	1
NBP adult cuff	1
Maternal SpO <sub>2</sub> patient lead	1
Maternal SpO <sub>2</sub> re-useable probe	1
Maternal temperature probe	1
TempHearts™ (for maternal temperature)	1

### Supplied as options (with any monitor in the FM800 range)

IUP lead	Pink
IUP single-use transducers	
Maternal ECG lead	Blue
NBP small adult cuff	
NBP large adult cuff	
Trolley	
Wall-mounting kit	

### Accessories supplied with all monitors in the FM800 range

Ultrasound gel	8oz
Printer paper	2 packs
Reference Manual	1
Getting Started card	1
Mother's guide to FM800 card	1

## 1.9 FM800 trolley or wall mounting

FM800 can be mounted on a trolley or wall mounting. A purpose-designed trolley is available. If FM800 is used with a trolley or wall mounting, then it must be attached to the trolley or wall mounting with the securing screw. Otherwise there is a danger of its falling off the trolley or wall mounting accidentally.

To assemble the trolley or wall mounting, follow the instructions supplied by the manufacturer.

To attach FM800 to the trolley or wall mounting:

- 1 Position FM800 on the trolley or wall mounting top so that the securing screw is in line with the threaded boss in the centre of the FM800 base.
- 2 Reach under the trolley or wall mounting top, and locate the securing screw.
- 3 Gently push up and secure the screw tightly.



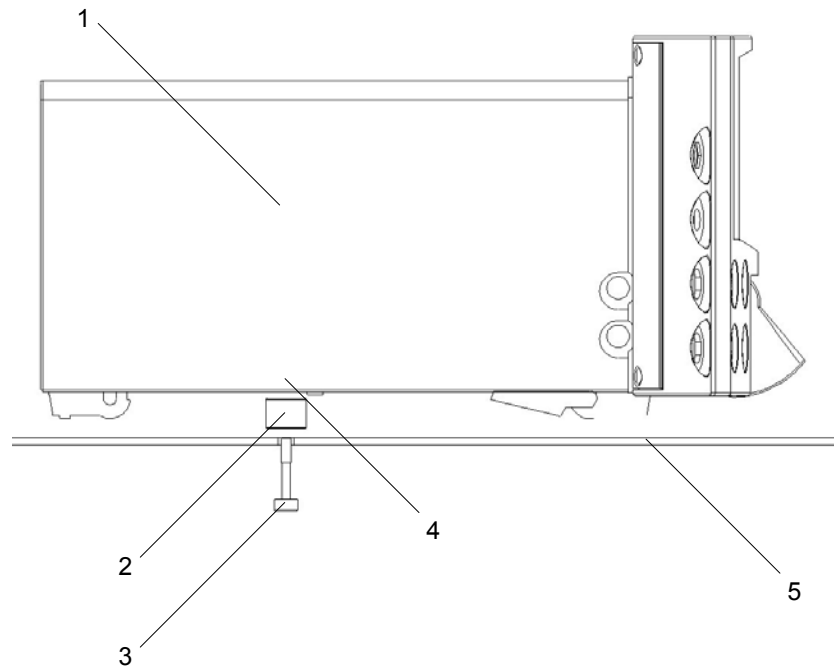





**WARNING:** if you use FM800 on a trolley, make sure the trolley brakes are applied at all times, except when the trolley is being moved.



1 FM800 unit    2 Spacer    3 Securing screw    4 Threaded boss  
5 Top of trolley or wall mounting unit

## 2 FM800 Controls and Display

### 2.1 Controls and on/off indicator

-  Printer on/off switch and indicator.  
Shows amber light when printer is switched on.
-  Audio volume down.
-  Audio volume up.
-  Printer fast forward.
-  Audio channel select. See Sections 5.2 and 6.3.
-  EasiNotes annotation. See Section 7.6.
-  Toco zero.
-  Power on/off switch and indicator.  
Shows green light when FM800 is switched on.
-  Power on/off symbol.

#### Switching on

To switch on, press the Power on/off switch.

If FM800 beeps rapidly and continuously, it has failed its power-up self-test routine.  
Contact your local Huntleigh Healthcare Ltd representative.

## 2.2 FM800 main screen

When FM800 is monitoring, fetal parameters are displayed down the left-hand side of the display, maternal parameters down the right-hand side. Each parameter is always displayed in the same position on the display. See diagram below.

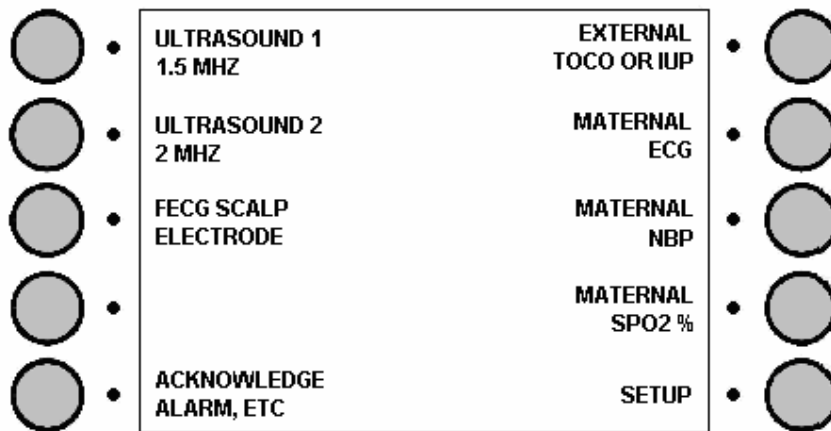

Buttons are not active until a transducer is connected. A triangular pointer indicates that a button is active.



Pressing a button takes you into a setup screen for that parameter. This setup screen allows you to set alarms and thresholds.

The setup button in the main screen is for general setup procedures (setting the time and date, altering the default thresholds, and so on).

Stop beep or make it quieter

FM800 beeps when you press a button or key. The loudness of the beep depends on the loudness of the fetal or maternal alarm, whichever is louder. So to make FM800 beep more quietly or loudly, change the volume of the fetal and/or maternal alarms. See Section 8.2.

To stop FM800 beeping when you press a button or key:

> SETUP > SYSTEM SETTINGS > access code (2755) > AUDIO/GRAPHIC > KEY PRESS



### 2.3 Software control buttons

When you switch FM800 on, the SETUP button is active. Other buttons are inactive. When you connect any transducer (apart from NBP), the button for that parameter becomes active, and the parameter name is displayed.

For example, when you connect Ultrasound 1, the display shows:

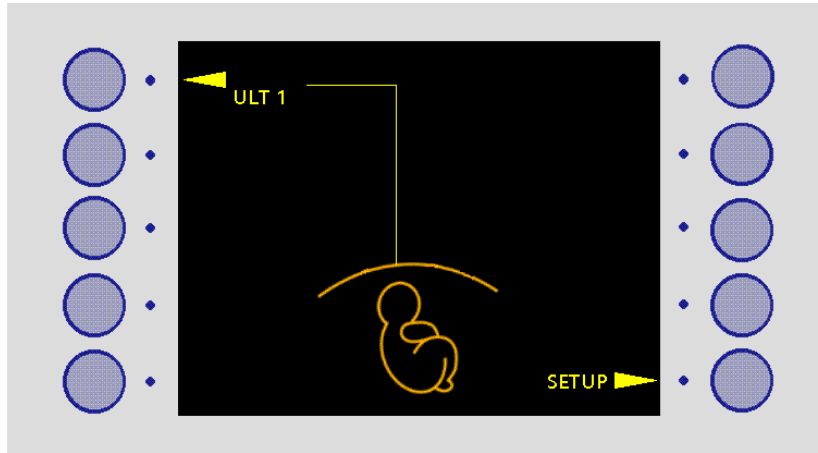

When the FM800 detects the fetal heart rate, it displays the rate and a confidence indicator (the heart symbol). See Section 5.4.

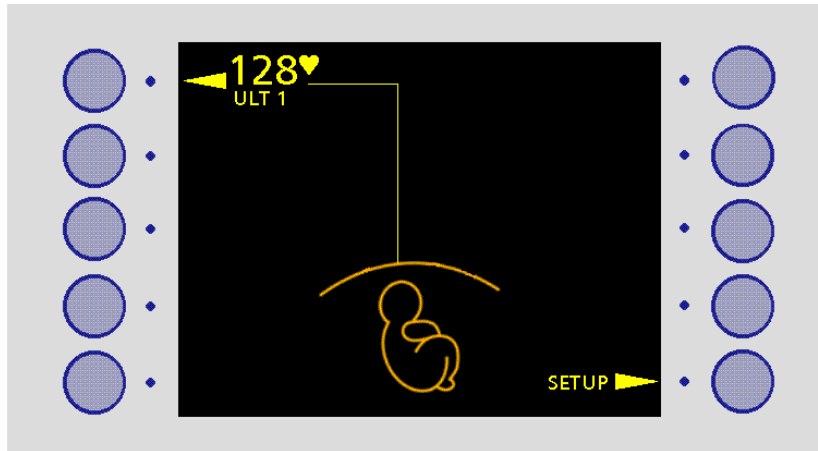

## 2.4 Audio controls

FM800 can give you an audio signal for one channel at a time (Ultrasound, FECG or MEEG). The default channel is ULT1 (1.5MHz Ultrasound). So if you switch on FM800 with transducers connected for all the audio channels, and then select audio, you will get an audio signal for ULT1. If you are in any doubt, the FM800 display shows you which channel currently has the audio signal.

For audio, see also Sections 5.2 and 6.3.

**Note:** in FM800s with firmware version 1.4.0 or later, if you connect an audio-capable transducer when audio is already turned on, the audio signal automatically switches to this most recently connected transducer.

The audio controls on FM800 allow you to:

- change the audio volume
- change the audio channel

### Volume control

To change the audio volume, press Audio Volume Up or Audio Volume Down.



Audio Volume Down



Audio Volume Up

### Changing the audio channel

To change the audio channel, press the Audio Channel Select button on the front panel of FM800 until the channel you want is selected.



Audio Channel Select

## 2.5 Printer controls

There are hardware controls for printer on/off, printer fast forward, and EasiNotes:



Printer On/Off switch and indicator.  
Shows amber light when printer is switched on.



Printer Fast Forward.



EasiNotes annotation. See Section 7.6.

### Printer setup

Printer setup is controlled by the software buttons (> SETUP > SYSTEM SETTINGS > access code (2755) > PRINTER). The options are:

- Twin FHR
- Print header
- Hospital name
- Paper speed
- FHR vertical scale
- FHR graticule
- Paper out buffer

See Section 4.3.

### EasiNotes setup

- > SETUP
- > SYSTEM SETTINGS
- > access code (2755)
- > EasiNotes.

See Section 7.6.

## 2.6 Loading printer paper

Note: the printer uses a thermal paper pack (part number 8400-8003), with no pre-printed graticule. If the paper pack shows a procedure for loading paper, this should be ignored, since it is relevant to Sonicaid Team, and not to the FM800.

- 1 Pull the FM800 paper drawer as far out as it will come (diagram A).
- 2 Remove the paper from its plastic wrapping. Make sure the words 'THIS SIDE UP' are visible, and that the arrow points to the back of the paper drawer.
- 3 Lift the first fold of paper towards you.
- 4 Place the paper pack centrally in the paper tray, with the first sheet centrally positioned over the roller (diagram B).
- 5 With a thumb on either side of the printer drawer, push the drawer in firmly until it clicks into place.

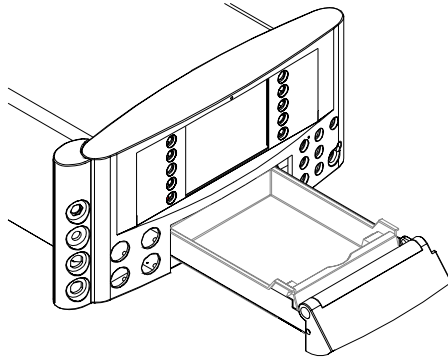

diagram A

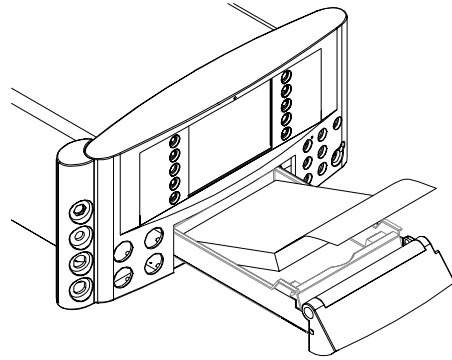

diagram B

## 3 Setup

### 3.1 Overview

The Setup procedures are much simpler if you understand the differences between Setup, Current Alarms, Default Alarms and System Settings.

Setup	User preferences available directly from the Setup screen.
Current Alarms	Allows you to set alarms before connecting transducers. Settings remain in force until you switch off FM800. When you switch on again, the FM800 reverts to the default alarms. You can set alarms for: FHR, Maternal temperature, MECG, NBP, MSpO <sub>2</sub> You can also set alarms from the main screen by pressing the key beside the parameter whose alarm you want to change.
Default Alarms	Default alarm settings protected by the access code (2755): Changes you make using Default Alarms remain in force when you switch FM800 off and on again.
System Settings	User preferences protected by the access code (2755): Changes you make using System Settings remain in force when you switch FM800 off and on again.

### 3.2 Current alarms

This option allows you to alter the alarms for a monitoring session before connecting transducers. The changes you make using this option do not remain in force when you switch off the FM800.

See Chapter 8.

### 3.3 Default alarms

This option allows you to alter the default alarms for the FM800. The changes you make using this option **do** remain in force when you switch off the FM800.

See Chapter 8.

### 3.4 System settings

See Chapter 4.

### 3.5 Analysis

Use SETUP also if you want to choose SonicaidCare\* (ante partum) or SonicaidTrend\* (intrapartum) analysis:

SonicaidTrend analysis	See Chapter 9.
SonicaidCare analysis	See Chapter 10.

*\* not approved for sale in USA and Canada*

### 3.6 Time and date

To reset the date or time in FM800:

- 1 > SETUP > TIME AND DATE.
- 2 > SETUP beside the time or date.
- 3 Use + and – to make the necessary changes.
- 4 > EXIT.

To change the date format, see Section 4.5, International Settings.

### 3.7 Patient details

Patient details are the patient name, patient ID and gestation period. They are printed on the header of the trace. They are not saved when FM800 is switched off.

Entering patient name and ID

To enter or edit the patient name and ID:

- 1 > SETUP > PATIENT DETAILS.
- 2 > ADD/EDIT beside Name or Number.
- 3 For each character of the name or ID:  
Press the key for the character group (eg ABCDEFGH).  
Then press the key for the character.  
To move the cursor: > LEFT or RIGHT.  
NB For non-standard characters: > NEXT PAGE.
- 4 When the name or ID is complete: > EXIT.

Gestation

To enter the gestational age of the fetus:

- 1 > SETUP > PATIENT DETAILS.
- 2 > ADD/EDIT beside Gestation.
- 3 > + or – as necessary.

To remove patient details

Switch FM800 off, then on.

### 3.8 Timer

You can set a timer to tell you when a given period of time (1–99 minutes) has elapsed. The timer starts when you start printing.

Note: you cannot set the timer when SonicaidCare analysis or SonicaidTrend analysis is in progress.

To set the timer

- 1 > SETUP > TIMER > ON.
- 2 Use + or – to set the length of time required.
- 3 > EXIT.

Acknowledging the timer

When the set time has elapsed, FM800 beeps repeatedly, if the beep is turned on.

In the main screen, the Alarm Acknowledge key shows the message:

TIMER FINISHED

To stop the beep: > ALARM ACKNOWLEDGE.

To turn the timer off

- > SETUP.
- > TIMER.
- > OFF.



### 3.9 Actogram settings

Actogram on/off (not available in the USA and Canada)

To turn the actogram features on or off:

- > SETUP
- > NEXT PAGE
- > ACTOGRAM

Press ACTOGRAM IS OFF/ON to turn the actogram feature on or off.

To increase or decrease the sensitivity of Actogram

- > SETUP
- > NEXT PAGE
- > ACTOGRAM
- > SET ACTOGRAM GAIN ULT1
- > use + or – to set the gain required.

Changing the Actogram display setting

- > SETUP
- > NEXT PAGE
- > ACTOGRAM
- > ACTOGRAM OUTPUT [this cycles on each press between graph, checkmarks and graph + checkmarks]

Changing the Actogram threshold

- > SETUP
- > NEXT PAGE
- > ACTOGRAM
- > SET ACTOGRAM THRESHOLD
- > use + or – to set the threshold as required.

[the required threshold may depend on whether the trace is showing a high incidence of artefact. It is recommended to set the threshold between 40 and 60%.]

Observe the Actogram trace for a short period to see if the setting is satisfactory.

## 4 System Settings and Default Alarms

### 4.1 Overview

The System Settings and Default Alarms screens allow you to set preferences which are protected by an access code (2755). These preferences remain in force when you switch the FM800 off, and then on again

#### System settings

The System Settings screen allows you to:

- Add or change EasiNote descriptions
- Display or not display the baby graphic
- Display or not display FECG or MECG waveforms
- Beep or not beep when a key is pressed
- Change the printer setup
- Change the international setup
- Beep or not beep when an Event Mark is recorded
- Select the host interface (eg Sonicaid FetalCare, System8002, Dopplex Centrale, Philips TraceVue)

You can also use System Settings to access Service information.

To get into the System Settings screen:

- > SETUP.
- > SYSTEM SETTINGS.
- > access code (2755).

#### Default alarms

The Default Alarms screen allows you to change the default alarms for:

- FHR
- Maternal temperature
- MECG
- NBP
- MSpO<sub>2</sub>

## 4.2 Changing the default alarms

When you switch the FM800 on, the alarm settings for FHR, maternal temperature, MEKG, NBP and MSpO<sub>2</sub>, and the mode setting for NBP, revert to the hospital defaults.

To change the hospital defaults:

- 1 > SETUP > DEFAULT ALARMS > access code (2755).
- 2 Press the key for the parameter whose default setting you want to change.
- 3 Change the alarm settings. See Section 8.1.

### Resetting to factory defaults

To restore FM800 configuration, as originally delivered from the factory:

- > SETUP.
- > SYSTEM SETTINGS.
- > enter access code (2755).
- > SERVICE CENTRE.
- > DIAGNOSTICS.
- > RESET TO FACTORY DEFAULTS.

## 4.3 Printer setup

### Print header

The header (hospital name, patient name, gestation) is printed at the start of the trace.

To switch header printing on or off:

- [> SETUP > SYSTEM SETTINGS > access code (2755)]
- > PRINTER.
- > PRINT HEADER once or twice, as required.

### Hospital name

To enter (or edit) the hospital name printed on the trace:

- > PRINTER.
- > HOSPITAL NAME.

Enter the hospital name in the same way as for Patient Details. See Section 3.7.

Paper speed

To change the paper speed:

- > PRINTER.
- > PAPER SPEED once or twice, as required.

FHR vertical scale

The FHR vertical scale can be 20 bpm/cm or 30 bpm/cm. At 20 bpm/cm the range is 50-210 bpm. At 30 bpm/cm it is 30-240 bpm.

To change the vertical scale:

- > PRINTER.
- > FHR SCALE.

FHR scale for twins

If you are monitoring twins, you can print each FHR trace on its own scale, or both on the same scale.

To alter the vertical scale for twins:

- > PRINTER.
- > TWIN FHR.

FHR graticule

The FHR graticule can be printed at intervals of 5 bpm or 10 bpm.

To alter the FHR graticule:

- > PRINTER.
- > FHR GRATICULE.

#### Paper-out buffer

If the paper runs out, FM800 can store data for up to 10 minutes, and then fast print when the paper is refilled until it catches up with the real-time incoming data. When this happens, the stored data is held in the paper-out buffer.

The default is for the paper-out buffer to be enabled (ie FM800 will store data if the paper runs out). To switch off the paper-out buffer, or switch it on again after it has been switched off:

- > PRINTER.
- > PAPER OUT BUFFER.

## 4.4 Audio/graphic settings

#### Baby graphic

To display (or stop displaying) the picture of a baby on the main FM800 screen:

[> SETUP > SYSTEM SETTINGS > access code (2755)]

- > AUDIO/GRAPHIC.
- > BABY GRAPHIC.

#### Audible key press

To switch on (or off) the beep which accompanies every key press:

- > AUDIO/GRAPHIC.
- > KEY PRESS.

#### Audible event mark

To switch on (or off) the beep which accompanies the marking of an event:

- > AUDIO/GRAPHIC.
- > EVENT MARK.

#### ECG waveform display

To display (or stop displaying) ECG waveforms when Maternal ECG or Fetal ECG is being recorded:

- > AUDIO/GRAPHIC.
- > ECG WAVEFORM.

**Note:** the waveforms appear only if an ECG signal is connected. But if you switch the instrument off, and then later switch it on again, it remembers whether you asked for ECG waveforms to be displayed.

## 4.5 International settings

Supply frequency (50Hz or 60Hz)

To alter the supply frequency:

- [> SETUP > SYSTEM SETTINGS > access code (2755)]
- > INTERNATIONAL.
- > SUPPLY FREQUENCY.

Language

To change the language appearing on the display:

- > INTERNATIONAL.
  - > LANGUAGE.
- Select the language you want.

Date format

To change the date format:

- 1 > INTERNATIONAL.
- 2 Press the key opposite the current date format.
- 3 Repeat if necessary.

If you want day, month and year separated by ‘.’:

- > ‘/’.

Contractions units of measurement

For Toco, the contractions scale is 0–100%, relative units.

For IUP, the units of measurement are mmHg (0–100) or kPa (0–15).

To select mmHg or kPa for the IUP transducer:

- > INTERNATIONAL.
- > IUP UNITS.

Temperature units of measurement (°C or °F)

To select °C or °F for the temperature transducer:

- > INTERNATIONAL.
- > TEMP UNITS.

## 4.6 Serial interface

When connecting to a central review system, you need to tell the FM800 whether the central review system is a Sonicaid system or a non-Sonicaid system which recognises the Philips Series 50 fetal monitors digital interface protocol.

FM800 has been tested with Sonicaid Centrale, Philips TraceVue and GMT Argus. For other central review systems, consult the description of the Serial Interface Protocol in the *Sonicaid FM800 Service Manual*, part number 329801, issue 3 or later.

To select the appropriate serial interface:

- 1 > SERIAL INTERFACE.
- 2 Use the key opposite 'RS232 S8002' to select the serial interface.  
For Sonicaid FetalCare or Sonicaid System8002, make sure the setting is 'Sonicaid'.  
For Sonicaid Centrale, Philips TraceVue or GMT Argus, make sure the setting is 'HP'.
- 3 > EXIT.
- 4 Switch off FM800. Wait for about 10 seconds.
- 5 Switch FM800 on again.

See also Chapter 11.

Note: GMT Argus is not approved for use with Sonicaid FM800 in the USA or Canada.

Note: Sonicaid Centrale can also support the 'Sonicaid' protocol option.

## 5 Monitoring Fetal Parameters

### 5.1 Preliminary

- 1 Have the transducers and transducer belts ready.
- 2 Switch on FM800.
- 3 Check the printer:
  - Is there sufficient paper for the monitoring session?
  - Is the drawer fully pushed in?
- 4 Check the printer setup (graticule, scale, paper speed etc).
- 5 Enter patient details, if required.

### 5.2 Audio signal

You can get an audio signal for FHR and Fetal ECG:

- For FHR the FM800 gives an audible representation of the Ultrasound signal.
- For FECG the FM800 beeps each time it detects a fetal heartbeat.

The volume control and channel select buttons are on the front panel of FM800. The channel select button selects the eligible channels in turn.

The eligible channels are those which:

- a) can produce an audio signal,
- and**
- b) have a transducer connected.

To select Audio for a channel, press Channel Select until the Audio symbol appears by that channel. To turn Audio off, press Channel Select until the Audio symbol does not appear at all.



Channel Select



Audio symbol



### 5.3 Ultrasound monitoring

- 1 Connect the yellow transducer to the yellow socket on FM800. In the FM800 main screen, the ULT 1 button becomes active.
- 2 Palpate the abdomen to determine fetal lie and position.
- 3 Make the patient comfortable in a semi-recumbent or sitting position. Place the belt around the abdomen, and secure it with the buckle.

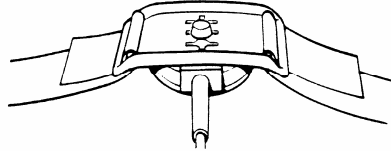

*Transducer buckle and belt attachment*

- 4 Apply Aquasonic coupling gel liberally to the face of the transducer. Position the transducer on the abdomen over the fetal site. Move it slowly until you hear the characteristic hoof-beat sound of the fetal heart.
- 5 When you are getting a good signal, FM800 displays the FHR. Check that the fetal heart pulse lamp flashes with each fetal heartbeat, and that the FHR is distinct from the maternal pulse rate taken at the mother's wrist. Make a note of the maternal pulse on the chart paper.
- 6 Clip the transducer through one of the three positioning holes on the buckle.
- 7 Connect the fetal event marker to the socket on the side panel. Explain to the mother how and when to use it.
- 8 Adjust the sound level with the volume controls on the front panel of FM800.
- 9 To start printing, press the printer on/off button.

Note: FM800 displays a schematic diagram of a fetus (or fetuses, if two transducers are connected) These diagrams do not show the actual position of the fetus. You can stop displaying this graphic, if you want. See Section 4.4.

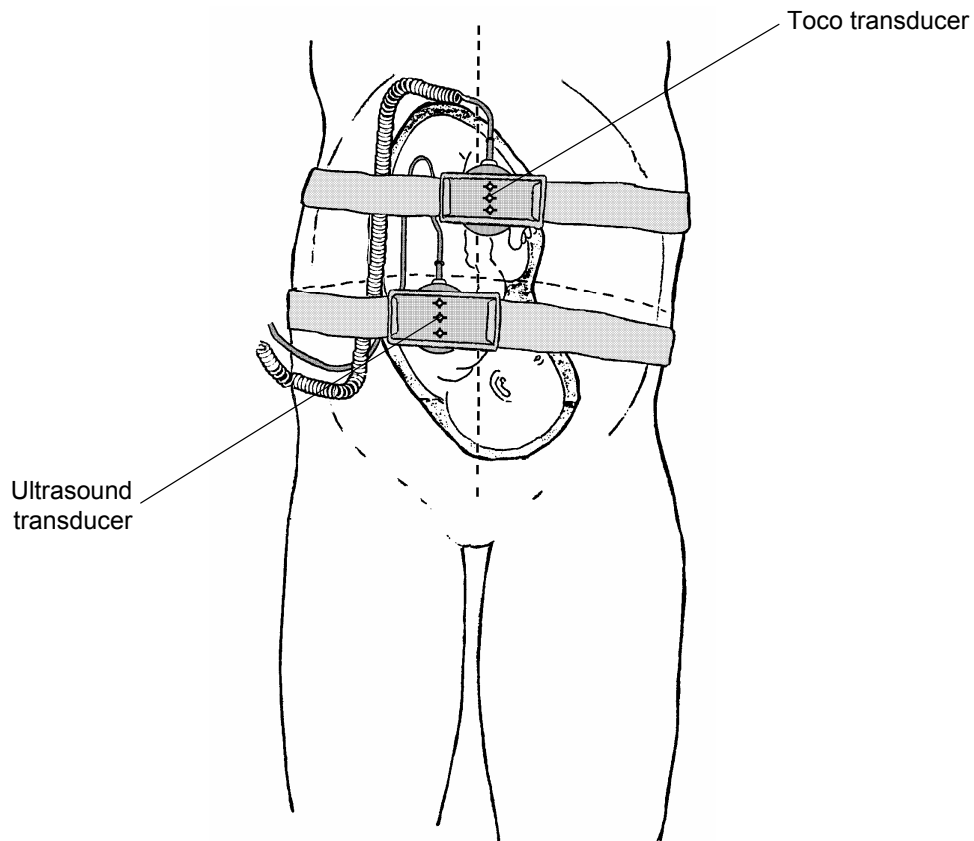

*Transducer positioning for  
Ultrasound monitoring*

#### Hints on monitoring

- Make sure the transducer is placed in the optimum position. Avoid positions with strong placental sounds (swishing) or the fetal cord pulse at the same rate as the fetal heart.
- If the fetus is in the occipitoanterior presentation and the mother is supine, the clearest heart sound will normally be found on the midline below the umbilicus.
- It is not possible to monitor the fetal heart rate unless an audible fetal heart signal is present. It is important to distinguish the fetal pulse from the maternal pulse. To do this, feel the mother's pulse during the examination, or monitor Maternal ECG.

## 5.4 The FHR confidence indicator

The heart symbol which appears against the FHR display is a confidence indicator, not an indicator of signal strength. See table below:

	Display shows	Interpretation
and	No heart symbol No FHR displayed	FM800 cannot detect the fetal heartbeat.
and	Heart symbol in outline only No FHR displayed	FM800 can detect a fetal heartbeat, but cannot determine the fetal heart rate.
and	Small heart symbol inside outline heart symbol FHR displayed	FM800 can detect the fetal heartbeat, and can establish a fetal heart rate, but not with a high degree of confidence.
and	Alternate small and large filled heart symbol ('beating' heart) FHR displayed	FM800 can detect the fetal heartbeat, and can establish the fetal heart rate with confidence.

## 5.5 False recording of low baseline FHR

When monitoring a low baseline FHR using Doppler ultrasound, the heart rate may be falsely reported. This effect is known as *double-counting*, and is characteristic of ultrasound fetal monitoring.

In normal circumstances the atrium and ventricle beat almost simultaneously. The ultrasound reflected from these two chambers is used by fetal monitors to calculate the FHR. When the FHR is low, at 70-80bpm, there is a longer time interval between the atrial and ventricular contractions. A fetal monitor may take the reflection from each chamber as a separate beat and therefore falsely calculate the FHR.

It can also happen, though very rarely, that the monitor double counts signals which are maternal in origin.

The Sonicaid FM800's heart rate detection system separates movements of the heart away from the transducer from those towards the transducer. This helps to correct some instances of double-counting, but does not entirely prevent it.

How to minimise the chances of double counting occurring

- 1 Always palpate the abdomen and listen to the fetal heart with a Pinard stethoscope or hand-held Doppler unit *before* applying the ultrasound transducers. This helps to verify the fetal heart and to locate the area where best signal quality can be expected.
- 2 Palpate the maternal pulse for one minute simultaneously and record it on the printed output.
- 3 Recording a signal for maternal ECG will help to identify any cross-correlation between maternal and fetal heart rates.
- 4 Listen to the fetal heart rate using the FM800 Audio signal. The sound should be like a galloping horse, not a swishing sound from maternal vessels.

## 5.6 Ultrasound for twins

- 1 Set FM800 to TWIN SCALES or SINGLE SCALE.  
[ > SETUP > SYSTEM SETTINGS > access code (2755) > PRINTER > TWIN FHR]
- 2 Palpate the abdomen and ascertain the lie of each fetus.
- 3 Place both ultrasound transducers on the patient's abdomen in the optimum position. Use the blue ultrasound transducer to monitor the first, presenting twin. Make the transducers secure with belts and buckles.
- 4 Check that the two heart rates are different. If the heart rates appear similar:  
FM800 beeps  
The display shows !CHECK TRACE FOR SAME HEART RATE  
The printer prints this  symbol on the trace  
Make sure you have positioned the transducers correctly.

- To hear the audio signal for each twin, press the Channel Select on the front of FM800. The Audio symbol shows which is the active audio channel.



- Connect the fetal event marker to the socket on the side panel. Explain to the mother how and when to use it.

### 5.7 Fetal ECG (using a scalp electrode)

#### Connection

For a single fetus:

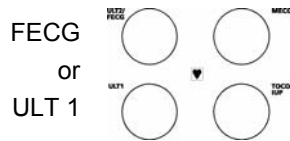

For twins:

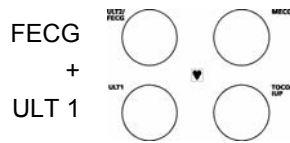

Note: In the USA and Canada the use of FDA-compliant fetal scalp electrodes is required.

Monitoring procedure using Sonicaid electrodes

- 1 Gel the base of the electrode leg plate, then strap the electrode leg plate to the front of the thigh. Secure with the belt.
- 2 Connect the electrode leg plate to either of the blue sockets on FM800.  
Caution: read the instructions for use supplied with the fetal ECG scalp electrode
- 3 Attach the fetal scalp electrode to the fetal scalp or the presenting part as described in the electrode instructions.
- 4 Connect the electrode leads to the leg plate. The polarity of these connections is not important. Make sure a good signal is maintained.
- 5 Allow a few minutes for the signal to stabilize and a clear fetal heart rate to be displayed. The signal quality indicator should be a solid, filled heart. Check the signal visually by displaying the FECG waveform (see below).
- 6 The FM800 carries out its own internal impedance check. If the check fails, you see the message: CHECK FECG CONNECTIONS.
- 7 Adjust the volume control as necessary.

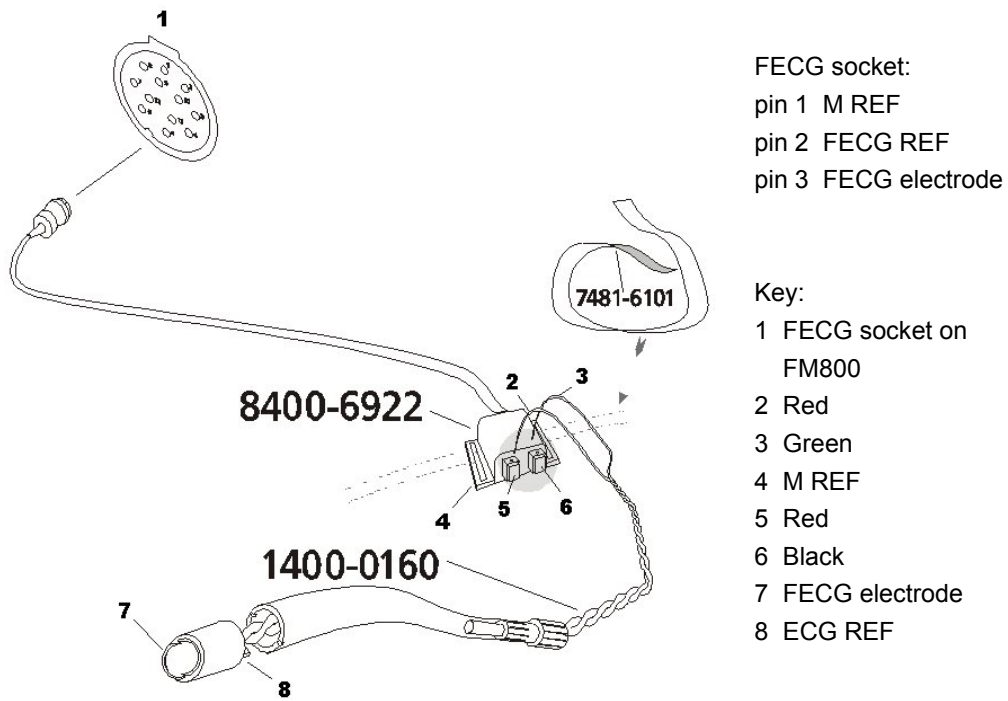

Monitoring procedure using Safelinc electrodes

Caution: follow the instructions for use supplied with the fetal ECG scalp electrode

- 1 Following the manufacturer's instructions, attach the FECG lead to the mother's leg, using the adhesive pad.
- 2 Following the manufacturer's instructions, attach the FECG electrode to the fetal presenting part.
- 3 Connect the FECG electrode to the FECG lead.
- 4 Allow a few minutes for the signal to stabilize and a clear fetal heart rate to be displayed. The signal quality indicator should be a solid, filled heart. Check the signal visually by displaying the FECG waveform (see below).
- 5 The FM800 carries out its own internal impedance check. If the check fails, you see the message: CHECK FECG CONNECTIONS.
- 6 Adjust the volume control as necessary.

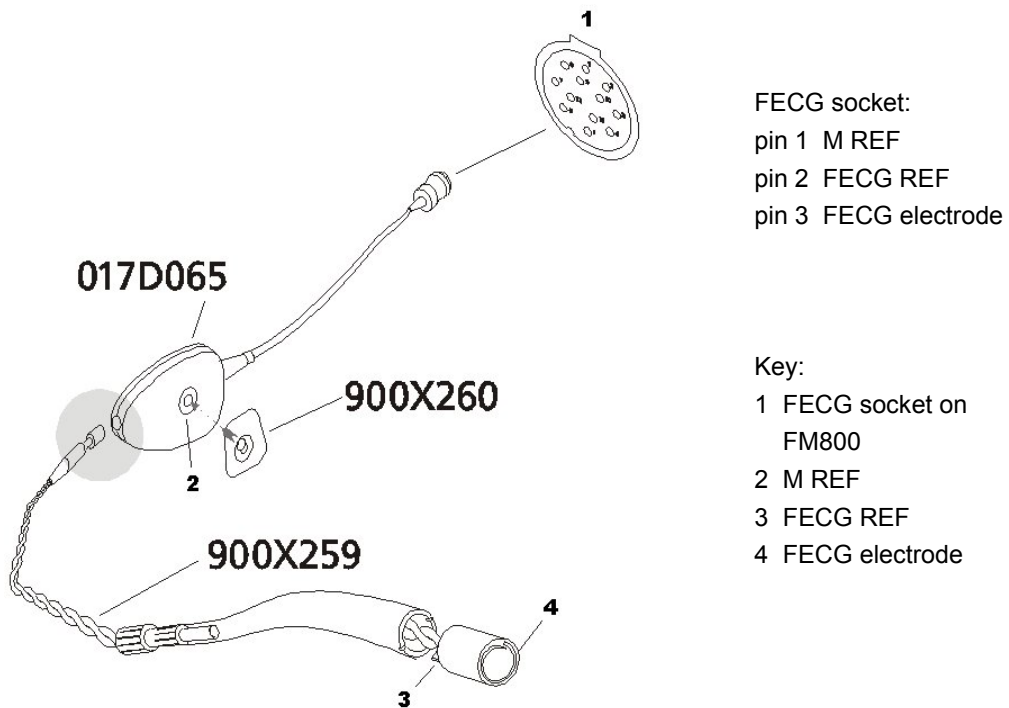

#### Displaying the FECG waveform

When you monitor FECG using a scalp electrode, the FM800 monitor shows the fetal heart rate in the same way as it shows the ultrasound heart rate: as a numerical rate together with the confidence indicator (the flashing heart symbol). There is also an option to display the FECG waveform.

The factory default is to display the waveform. So a brand new FM800 will display FECG waveforms if there is an FECG transducer connected. From then on the FM800 remembers the on/off setting from the last time it was used.

To switch the display on:

- > SETUP.
- > SYSTEM SETTINGS.
- > access code (2755).
- > AUDIO/GRAPHIC.
- > ECG WAVEFORM.
- > EXIT > EXIT.

The FECG waveform now appears in place of the baby graphic:

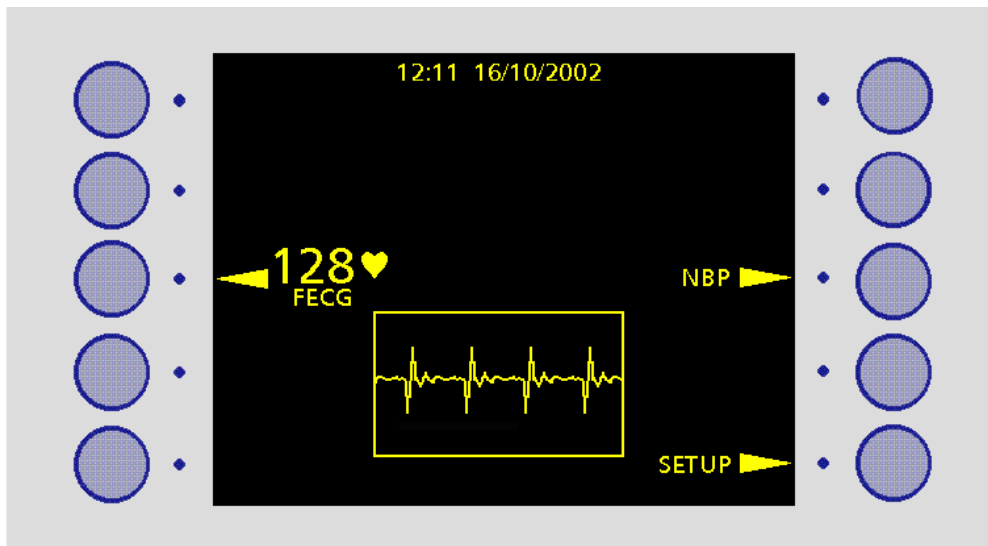

**Note:** if you are monitoring MEEG and FECG, and ECG waveform display is switched on, the FM800 displays the MEEG waveform. To see the FECG waveform displayed, disconnect the MEEG transducer from the FM800.



Printing the FECCG waveform

- 1 Make sure the FM800 is already printing the trace.
- 2 Make sure the FECCG waveform is displayed.
- 3 > the EasiNotes annotation button.
- 4 > PRINT ECG.



FECCG trace printout:

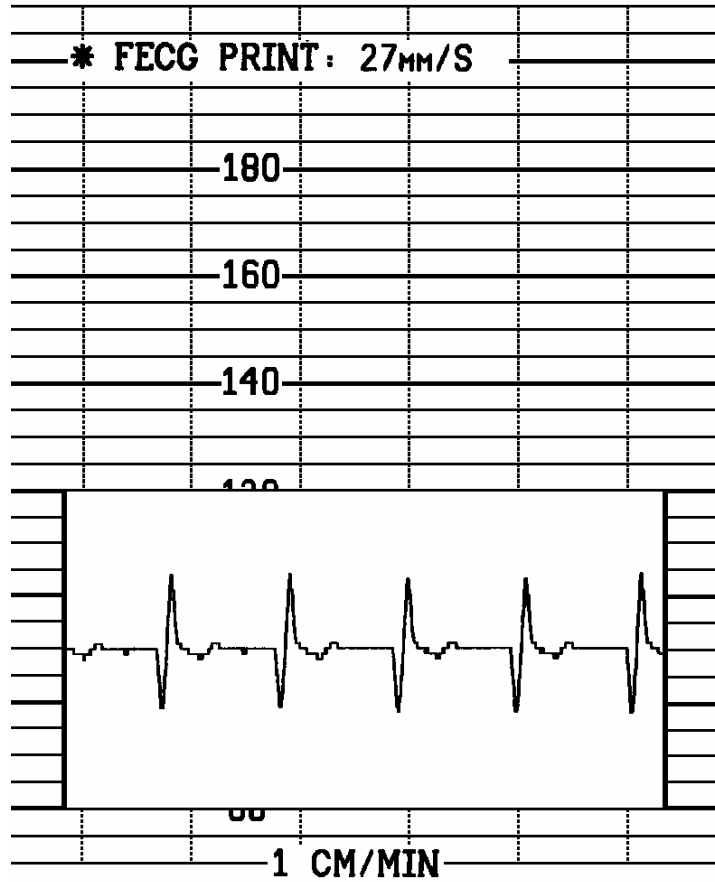

## 5.8 Accidentally recording the wrong signal

We have seen (section 5.6) that when you are monitoring twins, it is possible to pick up the signal for the 'wrong' twin. It is also possible, if the ultrasound transducer is incorrectly placed, for it to pick up the maternal heart instead of the fetal heart. Similarly it is possible for the maternal ECG to be mistaken for the fetal ECG. To help guard against these possibilities, the FM800 routinely compares the heart rates obtained from different sources. If any two rates appear similar (within 3bpm), for more than three minutes, then:

FM800 beeps

The display shows

!CHECK TRACE FOR SAME HEART RATE

The printer prints this

symbol on the trace



The message and warning are the same no matter what two rates are similar.

If the rates continue to match, the warning is repeated every 2 minutes 30 seconds.

If the FM800 gives you this warning, you should check that the signals you are recording are what you think they are. The following pairs of rates are compared:

ULT1 with ULT2

ULT1 with FECG

ULT1 with MECCG

ULT1 with MSpO2 (heart rate)

ULT2 with MSpO2 (heart rate)

FECG with MSpO2 (heart rate)

FECG with MECCG

ULT2 with MECCG

## 6 Monitoring Maternal Parameters

### 6.1 Contractions (using Toco transducer)

- 1 Connect the Toco transducer to the pink socket on FM800.
- 2 Place the belt round the abdomen, and secure it with the buckle.
- 3 DO NOT USE COUPLING GEL. Wipe off any gel present on abdomen around this area.
- 4 Clip the Toco transducer through one of the three positioning holes on the buckle so that it is retained on the midline half-way between the mother's fundus and the umbilicus.
- 5 Contractions activity is measured as a % of full scale deflection. The contractions measurement automatically zeroes to 10%. If you suspect the transducer is not zeroed correctly, press the pink Toco Zero button on the front of FM800, at a moment when the mother is not experiencing a contraction.



## 6.2 Contractions (using IUP transducer)

FM800 is designed for use with an Intran disposable catheter transducer.

- 1 Connect the IUP connecting lead to the pink socket on FM800.

Caution: read the instructions for use supplied with the intrauterine catheter.

- 2 Set IUP units of measurement, if required.

[SETUP > SYSTEM SETTINGS > access code (2755) > INTERNATIONAL > IUP UNITS]

- 3 Insert the catheter as described in the instructions.

- 4 Zero the transducer as described in the instructions supplied with it.

Zero FM800 by pressing the pink Toco Zero control on the front panel.

Or > IUP, then > ZERO.



- 5 To confirm placement and function of the transducer, ask the patient to cough. You should observe a spike in the contractions measurement.

- 6 Connect the fetal event marker to the socket on the side panel. Explain to the mother how and when to use it.

## 6.3 Maternal ECG

Monitoring MEEG allows you to check that the fetal heart rate being recorded does in fact belong to the fetus and not the mother.

### Audio signal

You can get an audio signal for MEEG. If you select Audio for MEEG, the FM800 beeps each time it detects a maternal heartbeat. The volume control and channel select buttons are on the front panel of the FM800.

To select Audio for MEEG, press Channel Select until the Audio symbol appears by the MEEG display. To turn Audio off completely, press Channel Select until the Audio symbol does not appear at all.



Channel Select



Audio symbol

MECG monitoring procedure

- 1 Use self-adhesive disposable electrodes. Placement of the electrodes is not critical, though it is a good idea to have the lower electrode placed clear of the diaphragm, as the muscles here are very active in contraction.

A recommended arrangement might be:

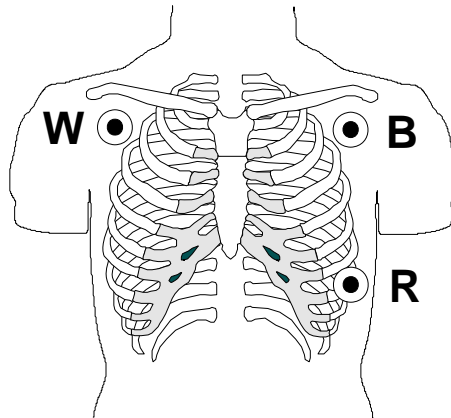

- 2 Connect the MECG lead (blue) to the MECG socket on FM800.
- 3 Clip the three flying leads of the MECG lead to the electrodes. They are colour-coded white, black and red (W, B and R in the diagram above).
- 4 Allow a few minutes for the signal to stabilize and a clear maternal heart rate to be displayed. Check the signal visually by displaying the MECG waveform (see below).
- 5 The FM800 carries out its own internal impedance check. If the check fails, you see the message: CHECK MECG CONNECTIONS.
- 6 If you have selected audio for the MECG channel, adjust the volume control as necessary.

If the maternal and fetal heart rates appear similar:

- FM800 beeps
- The display shows **!CHECK TRACE FOR SAME HEART RATE**

Confirm the source of the fetal heart rate you are monitoring.

#### Displaying the MECG waveform

When you monitor MECG, the FM800 monitor shows the maternal heart rate in the same way as it shows the ultrasound heart rate: as a numerical rate together with the confidence indicator (the flashing heart symbol). There is also an option to display the MECG waveform.

The factory default is to display the waveform. So a brand new FM800 will display MECG waveforms if there is an MECG transducer connected. From then on the FM800 remembers the on/off setting from the last time it was used.

To switch the display on:

- > SETUP.
- > SYSTEM SETTINGS.
- > access code (2755).
- > AUDIO/GRAPHIC.
- > ECG WAVEFORM.
- > EXIT > EXIT.

The MECG waveform now appears in place of the baby graphic:

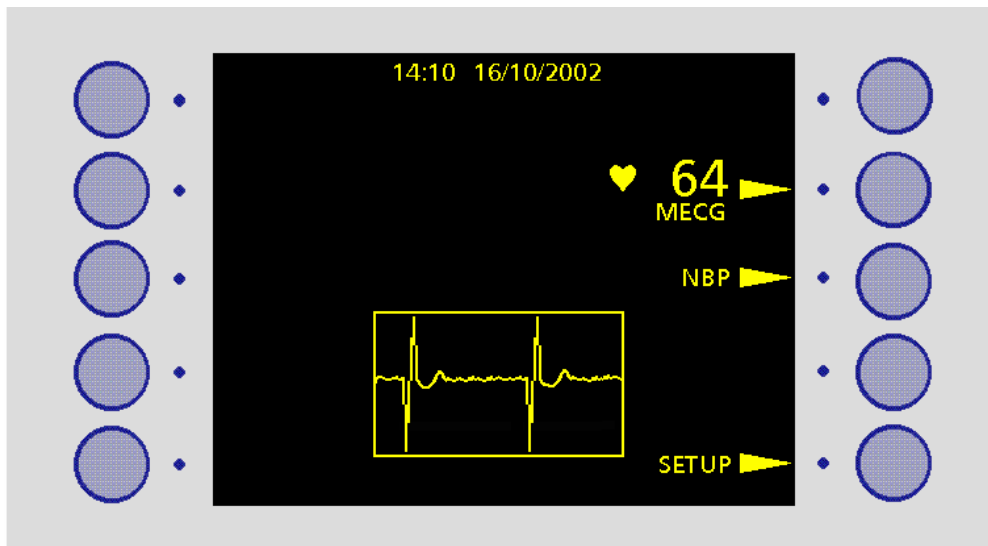

**Note:** if you are monitoring MECG and FECG, and ECG waveform display is switched on, the FM800 displays the MECG waveform.

Printing the MEEG waveform

- 1 Make sure the FM800 is already printing the trace.
- 2 Make sure the MEEG waveform is displayed.
- 3 > the EasiNotes annotation button.
- 4 > PRINT ECG.



MEEG trace printout:

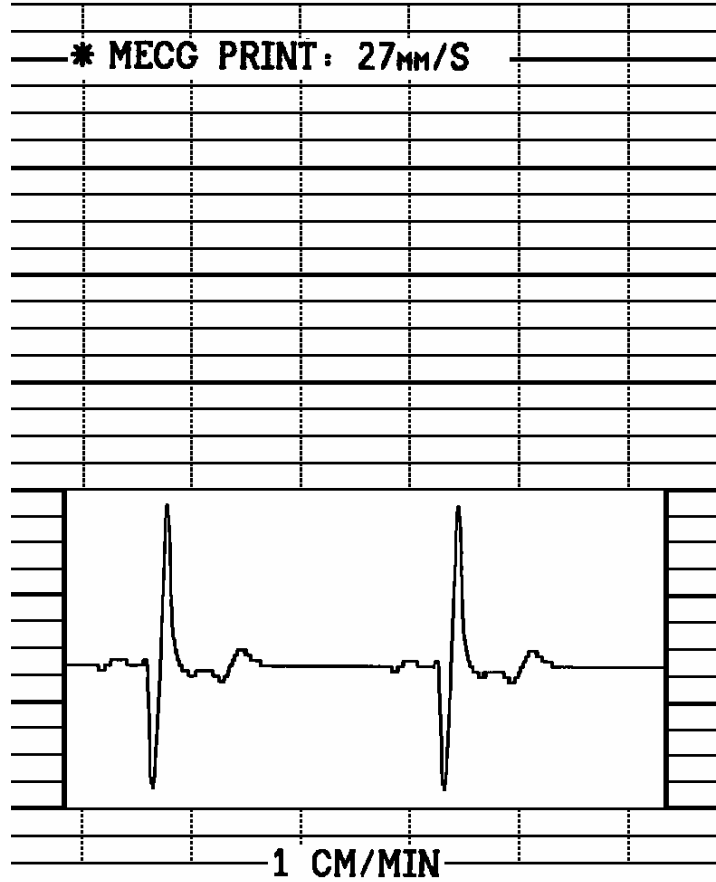

## 6.4 Maternal Blood Pressure

The FM830 can measure the mother's systolic and diastolic blood pressure, mean arterial pressure\*\*, and the average pulse rate during the measurement. You can take measurements manually or automatically (at an interval defined by the user).

An alarm is triggered if the mother's blood pressure goes above or below certain limits, or if the measurement fails. You can switch the alarm off, if you prefer.

\*\* This feature not available in the USA or Canada

**Note:** in countries where mean arterial pressure is not used, the value for mean arterial pressure is not shown on the FM800 printout. Any obstetric data management system connected to FM800 should be configured not to display the mean arterial pressure.

### Attaching the cuff

- 1 Place the cuff around the mother's arm, approximately 5cm above the elbow.
- 2 Connect the cuff hose to the FM800 air hose.
- 3 Connect the FM800 air hose to the NBP connector on the FM800 patient module.

### Displaying results

FM800 displays systolic and diastolic pressure, in the format **135/75**, beside the NBP button. This result is displayed for an hour, or until the next NBP measurement.

If you are not monitoring maternal ECG or maternal oximetry, FM800 also displays the average pulse rate during the last NBP measurement. This value is displayed beside the MEEG button for 10 minutes, or until the next NBP measurement.

**Note:** if you are taking NBP measurements every 3 minutes, set print speed to 2cm/min or 3cm/min; otherwise there will not be room on the paper for every result.



#### Taking measurements manually

- 1 Connect the cuff to the NBP socket on the connector module.
- 2 > NBP. The NBP SETUP screen tells you whether you are in Manual Mode or Auto Mode.
- 3 To change from Auto to Manual: > MANUAL.
- 4 The ALARMS symbol tells you whether the alarm is on or off.



Alarm on



Alarm off

To turn the alarm on or off: > ALARMS > ON or OFF. If you set the alarm on, you can reset the alarm limits and volume, if necessary. See Chapter 8.

- 5 Attach the cuff to the mother. See above.
- 6 To take a measurement: > NBP > START MEASUREMENT.  
To stop a measurement, after it has started: > STOP NBP.

#### Taking measurements automatically

- 1 Connect the cuff to the NBP socket on the connector module.
- 2 > NBP > AUTO.
- 3 Set the interval between measurements by pressing **+** or **-**.
- 4 The alarm symbol tells you whether the NBP alarm is on or off.



Alarm on



Alarm off

To turn the alarm on or off: > ALARMS > ON or OFF. If you set the alarm on, you can reset the alarm limits and volume, if necessary. See Chapter 8.

- 5 Attach the cuff to the mother. See above.
- 6 > START AUTO CYCLE to start taking measurements.
- 7 To take a non-automatic measurement, while remaining in Auto Mode:  
> NBP > MEASURE NOW.
- 8 To stop taking measurements: > NBP > STOP AUTO CYCLE.  
To stop a particular measurement: > STOP NBP. FM800 remains in Auto Mode, and displays **00/00** as the current measurement.

Failed measurements (manual and automatic)

When an NBP measurement fails:

- The NBP display shows **00/00**.
- An error code or message explains why the measurement failed. See Section 13.4.
- An audible alert sounds, if NBP alarms are on.

If there is an error condition in Auto Mode, the Auto cycle is halted, but FM800 remains in Auto Mode. To restart automatic measurements: > NBP > START AUTO CYCLE.

Note: if the error is over-pressure (code 906), the alert always sounds.

## 6.5 Maternal Oximetry

The FM830 can measure the mother's blood oxygen saturation and pulse rate. An alarm sounds if the mother's oxygen saturation drops below a certain level, or if her pulse rate goes above or below certain limits. If you are monitoring Maternal ECG, the MEECG heart rate overrides the pulse rate from the oximeter.

### Caution

- 1 Use only maternal oximetry sensors which have been approved and licensed by the manufacturer. Always follow the instructions for use supplied with the maternal oximetry sensor.
- 2 The maternal oximetry sensor will not give accurate results if the mother is wearing nail varnish.
- 3 Nail varnish remover contains acetone. Contact with acetone will damage the maternal oximetry sensor.

WARNING

Do not use the maternal oximetry sensors during magnetic resonance imaging (MRI) scanning. Induced current could cause burns. The oximeter may affect the MRI image, and the MRI unit may affect the accuracy of oximetry measurements.

Procedure

- 1 Connect the maternal oximetry sensor to the maternal oximetry module.
- 2 Connect the oximetry module to the FM800 connector module. Align the red dot on the oximeter lead with the red dot on the MSpO<sub>2</sub> socket on the FM800 connector module. Push the connector straight in until it locks. Do not twist.
- 3 Attach the sensor to the mother. See the instructions supplied with the sensor.
- 4 The 'searching' symbol appears while the sensor looks for an oximetry signal.
- 5 When it finds a signal, the 'searching' symbol disappears, and is replaced by the 'pulse amplitude' and 'signal quality' symbols.
- 6 Reset the alarm limits and alarm volume, if necessary. See Chapter 8.
- 7 If you want an audible pulse tone, press Channel Select until the Audio symbol appears by the MSpO<sub>2</sub> display.



Channel Select



Audio symbol

- 8 Start monitoring. Check the pulse tone volume, if Audio is selected.

Note: if FM800 does not display the 'Searching' symbol in step 4, make sure the oximetry sensor is connected to the oximetry module.

Guide to MSpO<sub>2</sub> symbols



Searching



Pulse  
Amplitude



Signal Quality: good



Signal Quality: poor

#### Start and stop monitoring

To start monitoring, in the MSpO<sub>2</sub> SETUP screen: > START. After about 5 seconds, the mother's blood oxygen level appears in the MSpO<sub>2</sub> section of the display, with a pulse amplitude indicator. If you are not monitoring Maternal ECG, the mother's pulse rate also appears.

If you have selected Audio for MSpO<sub>2</sub>, the pulse beat is indicated by an audible 'pulse tone', which sounds with each beat of the mother's pulse.

#### Disconnecting the oximetry sensor

When the oximetry module is connected to FM800, the connection is secured by two catches. These catches are released when you pull the knurled metal sleeve of the oximetry module connector (this sleeve is the part with the red dot on it). So when you disconnect the oximetry module from FM800, be sure to hold it by the knurled metal sleeve.

#### Caution

If you try to disconnect the oximetry module by pulling on the lead, then  
a) you won't succeed,  
and b) you may damage the connector module.

## 6.6 Maternal temperature

- 1 Position the temperature probe on the mother (a position on the inside of the upper arm is recommended).
- 2 Secure the probe with a TempHeart<sup>□</sup> (TempHearts are heart-shaped silver stickers).
- 3 Set the temperature alarms, if required. See Section 8.7.
- 4 Connect the temperature probe lead to the TEMP input on the FM800 connector module. FM800 starts taking readings for Maternal Temperature as soon as you attach the Temperature probe to the mother.
- 5 Wait about 5 minutes for the displayed temperature reading to stabilise.

To change the units of measurement:

- > SETUP > SYSTEM SETTINGS > access code (2755).
- > INTERNATIONAL.
- > TEMP UNITS.

## 7 Events and Alarms

### 7.1 What is meant by an alarm?

During most monitoring sessions things occur which are to some extent unexpected or outside normal routine. These are referred to collectively as alarms, even though many of them are not in the least alarming. They include:

- Signal going outside the normal range
- Loss of signal
- Elapsed time counter
- Failure of the FM800 unit

Of these, the first requires the attention of a midwife or doctor. The signal going outside the normal range is sometimes cause for alarm and sometimes not.

Other so-called alarms are unlikely to be cause for alarm at all.

### 7.2 What do you see and hear?

Audible indicators

FM800 has five different beep tones. These indicate:

- Fetal alarms (highest tone)
- Maternal alarms
- Key presses, general warnings, fetal event by marker button or Actogram
- Fetal pulse rate from FECG
- Maternal pulse rate from MEEG or MSpO<sub>2</sub> (lowest tone)

**Visual indicators**

**Type of alarm**

**What you see and hear**

Signal outside range

The alarm beeps sound and the ALARM ACKNOWLEDGE key becomes active. The value which is out of range, and the arrow adjacent to the ALARM ACKNOWLEDGE message, flash alternately

Signal loss, Ultrasound/FECG  
Signal loss, contractions/MECG

The alarm beeps sound and the ALARM ACKNOWLEDGE key becomes active. The 'lost parameter', and the arrow adjacent to the ALARM ACKNOWLEDGE message, flash alternately.

Signal loss, oximetry

The Heart symbol flashes and an alarm beep sounds (Fetal Oximetry only). The sensor lifted signal may appear if this is the cause of the signal loss.

Signal loss, blood pressure

No NBP value  
An alarm beeps 5 times, and a message explains why (eg 'movement', 'air leak')

Coincidence alarms  
(see section 5.6)

A single warning beep and the message:  
'!CHECK TRACE FOR SAME HEARTRATE'

Fetal events

Triangular marker at the top of the FHR trace

Clinical events

**\*** printed on FHR trace, with space for manual annotation  
**OR** Clinical event notes above the FHR trace

Timer

Message:  
 Alarm Acknowledge  
TIMER FINISHED

FM800 failure

**EITHER** a blank screen  
**OR** an error message

### 7.3 Responding to alarms

<b>Type of alarm</b>	<b>Recommended user response</b>
Signal outside range	Acknowledge alarm Doctor or midwife to decide what action to take
Loss of signal	Acknowledge alarm, if appropriate For FHR: reposition the transducer For other parameters: check transducer attachment and connections
Timer	Depends on why you set the timer in the first place
FM800 failure	<ol style="list-style-type: none"><li>1 Stop monitoring.</li><li>2 Remove transducers from mother.</li><li>3 If there is an error message, make an exact note of what it says.</li><li>4 Return FM800 to Huntleigh Healthcare Ltd or their local representative.</li></ol>

#### Acknowledging alarms

To acknowledge an alarm: > ALARM ACKNOWLEDGE in the main screen. This turns off the audible alarm and resets the counters on which the calculation of alarm states is based. The visual indication continues – ie the value which is out of range continues to flash.

If more than one alarm has been triggered, ALARM ACKNOWLEDGE turns them all off.



## 7.4 Controlling alarms

There are four ways you can control an alarm:

- Acknowledge it (ie silence it) when it occurs. See Section 7.3.
- Switch it off, so that it is never triggered.
- Alter thresholds so that it occurs more frequently or less frequently.
- Alter the volume of the audio alarm.

Switching alarms off

To switch an alarm off, press the parameter key, then OFF, then EXIT.

Altering alarm thresholds and volume

See Chapter 8.

## 7.5 Recording fetal movements

The mother can record fetal movements using the fetal event marker. A triangular event mark is printed at the top of the fetal heart rate trace, and FM800 beeps, if the audible beep is switched on.

- 1 Connect the event marker to the jack socket on the side of FM800.
- 2 Give the event marker to the mother. Tell her to press the button every time she feels a fetal movement.

To turn the audible beep off or on

- 1 > SETUP > SYSTEM SETTINGS > access code (2755).
- 2 > AUDIO/GRAPHIC > EVENT MARK.
- 3 > EXIT.

## 7.6 Actogram

**Note:** the Actogram feature is not available in the USA and Canada.

Actogram uses the low-frequency content of the signal from the 1.5 MHz ultrasound transducer to detect fetal movements, and give an activity profile of the fetus.

**WARNING: ACTOGRAM IS NOT INTENDED FOR USE DURING LABOUR.**

Recorded activity represents fetal movements (breathing, limb and trunk movement) or non-fetal movements (transducer movement, maternal coughing or other movement).

The Actogram value can be printed as a line graph on the contractions trace, or as fetal event marks above the trace, or both. An event mark is printed every time the amplitude goes above a set threshold. The default threshold is 40% of full scale deflection, but it can be set to any value in the range 0–99%.

In a study of 14 near-term normal fetuses with the threshold set at 40%, the sensitivity and specificity of the Actogram function (compared with scanner-identified breathing, limb movement and trunk movement) were 96% and 68% respectively. This data is published with the kind permission of Professor David James of the Department of Obstetrics and Gynaecology, Queens Medical Centre, Nottingham.

### Data storage

FM800 does not store the Actogram event marks, activity graph or threshold value.

### Twins

Actogram works from information collected only from the 1.5 MHz transducer, but it may also sometimes detect fetal movements from the other twin. To minimise this effect, position the 1.5 MHz and 2.0 MHz transducers as far apart as possible and advise the mother to remain as still as she can.

Actogram graph and event marks

The following illustration shows Actogram graph and event marks superimposed on the contractions trace.

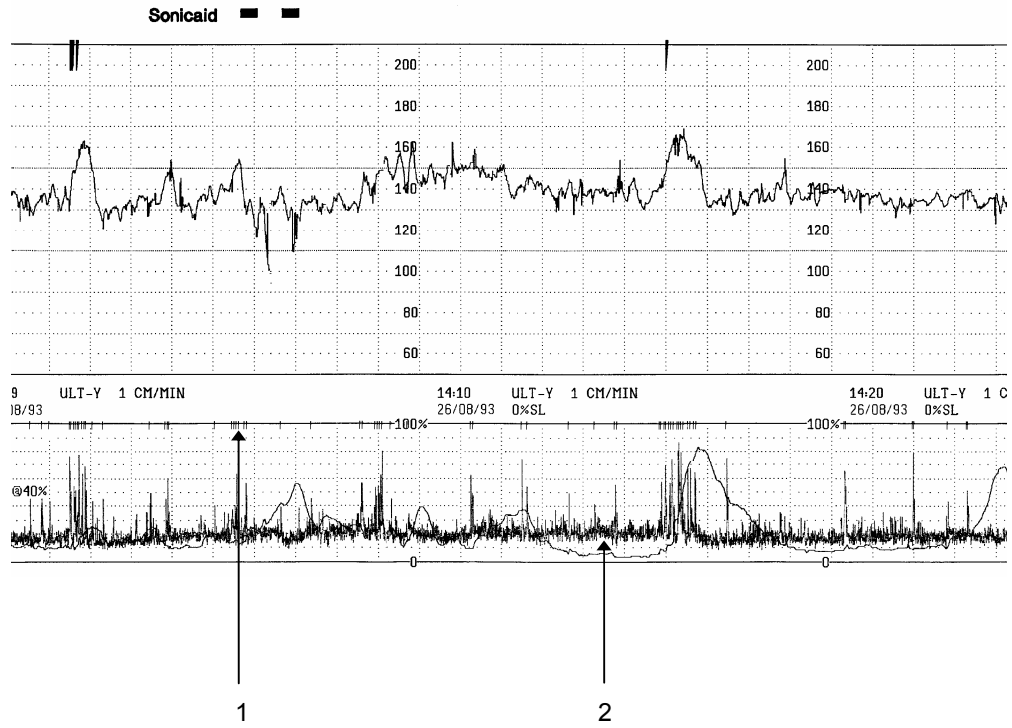

1 Actogram event marks

2 Actogram graph

## 7.7 Recording clinical events (EasiNotes)

EasiNotes allow you to record clinical events as clinical event notes above the fetal heart rate trace. If you try to record a clinical note when there is not enough room on the trace for one, the FM800 records a clinical event mark instead.

To enter a clinical event note or mark

- 1 Press the EasiNotes button on the front panel of FM800.
- 2 Open a submenu (Drugs, Position, etc).
- 3 Choose an item from the submenu.



OR To enter a mark: > MARK.

[Add a handwritten note to the trace, if required]

- 4 > EXIT.

To edit EasiNotes

- 1 > SETUP > SYSTEM SETTINGS > access code (2755).
- 2 > EasiNotes.
- 3 Open a submenu (Drugs, Position, etc), then edit the notes using the same text editing procedure as for Patient Details (see Section 3.7).
- 4 When you have finished editing: > EXIT.

To restore the default EasiNotes

- 1 Set the screen display to a language other than the one currently displayed.  
[SETUP > SYSTEM SETTINGS > access code (2755) > INTERNATIONAL > LANGUAGE]
- 2 Then reset the screen display to your own language.

## 8 Setting Alarm Thresholds

### 8.1 Default alarm thresholds

FM800 comes with factory-set alarm thresholds for all parameters:

Parameter	High	Low	Status
ULT 1, ULT 2, FECG	160 bpm	110 bpm	Off
FHR Signal Loss	30 %	None	Off
MECG	120 bpm	50 bpm	On
Maternal Blood Pressure, Systolic	160 mmHg	90 mmHg	On
Maternal Blood Pressure, Diastolic	90 mmHg	50 mmHg	On
Maternal Oximetry	None	94 %	On
Temperature	37.5°C	34.0°C	Off

#### Changing thresholds

If you change the current thresholds, the changes you make remain in force until you switch off FM800. If you change the default thresholds, the changes you make remain in force permanently. The screens for changing current and default thresholds are the same. The only difference is the option you need to select to access the screen.

To access the current alarm thresholds screen:

- > SETUP
- > CURRENT ALARMS

To restore the default thresholds, switch FM800 off and on again.

To access the default alarm thresholds screen:

- > SETUP
- > DEFAULT ALARMS
- > access code (2755)

Changing FHR thresholds is explained in some detail. The procedure for changing other thresholds is so similar that it is explained much more briefly.

## 8.2 FHR thresholds (Ultrasound and FECG)

To change the thresholds for FHR (Ultrasound 1, Ultrasound 2 or FECG), press ULT 1, ULT 2 or FECG in the main screen. The FHR SETUP screen appears.

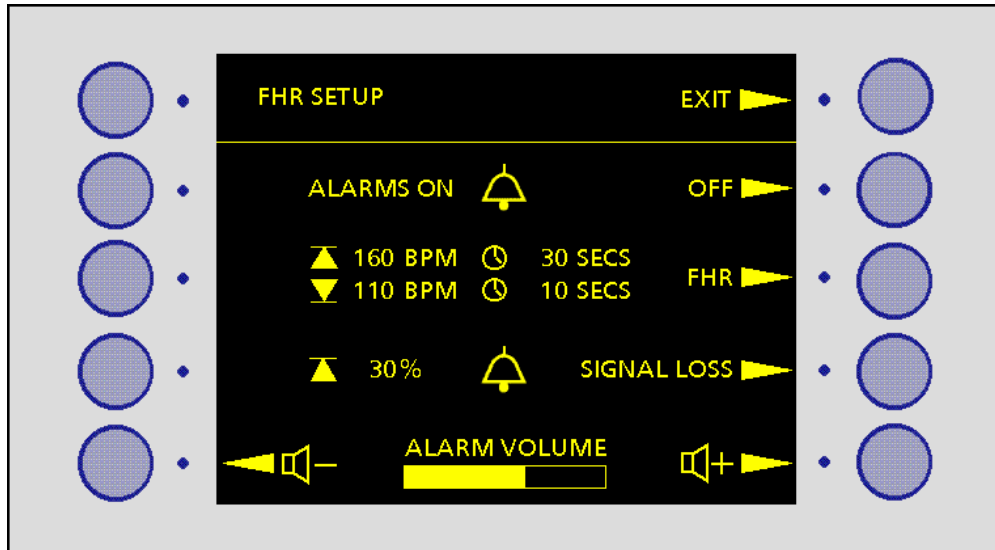

There are three conditions which can trigger an alarm:

- |             |  |
|-------------|--|
| High FHR    | FHR rises above a defined level for a defined period.<br>Default: 160 bpm for 30 seconds or longer.  |
| Low FHR     | FHR falls below a defined level for a defined period.<br>Default: 110 bpm for 10 seconds or longer.  |
| Signal Loss | More than a given percentage signal loss in a defined period.<br>Default: 30% in the last 5 minutes. |

For High and Low FHR you can change the defined level and the duration. For Signal Loss you can change the defined percentage.

High FHR or Low FHR

To change the limit or delay for High or Low FHR, press FHR:

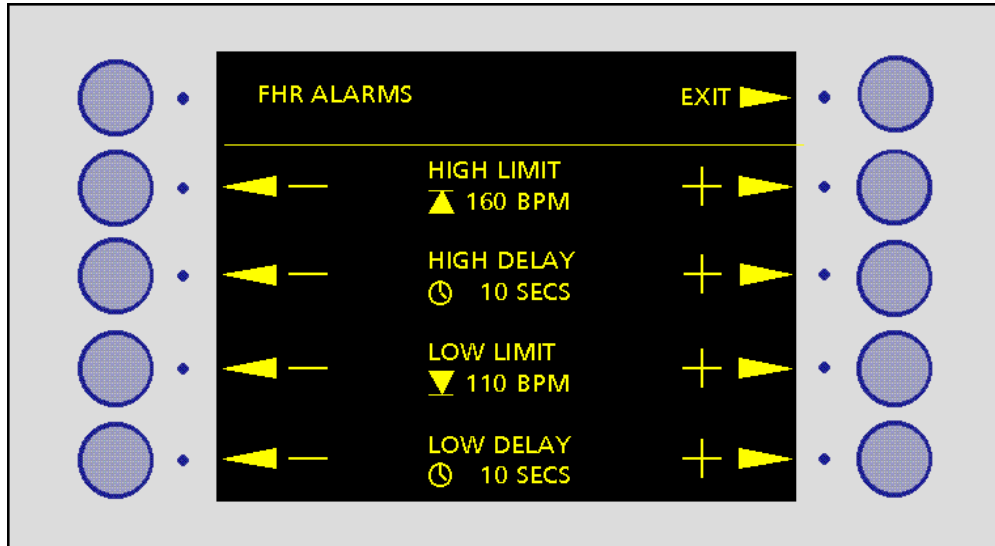

To change the high limit:

> HIGH LIMIT + or HIGH LIMIT -

To change the high delay:

> HIGH DELAY + or HIGH DELAY -

To change the low limit:

> LOW LIMIT + or LOW LIMIT -

To change the low delay:

> LOW DELAY + or LOW DELAY -

When you have set the new alarm levels: > EXIT.

#### Alarm volume

To change the volume of the audio alarm, use the ALARM VOLUME controls in the FHR SETUP screen:



#### Switching off the High FHR and Low FHR alarm

In the FHR SETUP screen: > OFF.

Note: this does not turn off the Signal Loss alarm.

#### Signal Loss alarm

To change the defined percentage:

- 1 > SIGNAL LOSS in the FHR SETUP screen.
- 2 To increase the percentage: > +  
To decrease the percentage: > -
- 3 > EXIT.

The Signal Loss alarm state ends when a continuous minute of signal has been received since the last alarm, or when the percentage signal loss for the last five minutes has fallen below the alarm threshold.

#### Switching off the Signal Loss alarm

From the FHR SETUP screen: > SIGNAL LOSS > OFF.

#### FHR alarms and signal loss

It may happen that the FHR goes beyond the FHR threshold, and then into signal loss, and that the next rate received is again beyond the FHR threshold.

The episode of signal loss is treated as:

Beyond the threshold	if signal loss < 50% of time period
Signal loss	if signal loss > 50% of time period

In the first case an alarm is triggered. In the second case an alarm is not triggered.



### 8.3 Maternal blood pressure thresholds

To change the thresholds for maternal blood pressure:

- 1 From the main screen: > NBP > ALARMS.
- 2 To change the Systolic or Diastolic high limit:  
> SYSTOLIC or DIASTOLIC  
> HIGH LIMIT **+** or HIGH LIMIT **-**

To change the Systolic or Diastolic low limit:

- > SYSTOLIC or DIASTOLIC  
> LOW LIMIT **+** or LOW LIMIT **-**

- 3 To change the alarm volume, use the ALARM VOLUME controls:



- 4 To turn the alarm off, in the NBP ALARMS screen: > OFF.
- 5 To return to the NBP SETUP screen: > EXIT.

### 8.4 MEKG thresholds

To change the thresholds for maternal ECG:

- 1 From the main screen: > MEKG > ALARMS.
- 2 To change the Bradycardia threshold (low limit):  
> LOW LIMIT **+** or LOW LIMIT **-**

To change the Tachycardia threshold (high limit):

- > HIGH LIMIT **+** or HIGH LIMIT **-**

- 3 To change the alarm volume, use the ALARM VOLUME controls:



- 4 To turn the alarm off: > OFF.
- 5 To return to the main screen: > EXIT.

## 8.5 Maternal oximetry threshold

To change the threshold for maternal oximetry:

1 From the main screen: > MSpO<sub>2</sub> > ALARMS.

2 To change the threshold for O<sub>2</sub> SAT:  
> LOW LIMIT **+** or LOW LIMIT **-**

3 To change the alarm volume, use the ALARM VOLUME controls:

 **+** Increase volume       **-** Decrease volume

4 To turn the alarm off: > OFF.

5 To return to the main screen: > EXIT.

## 8.6 Temperature thresholds

To change the thresholds for maternal temperature:

1 From the main screen: > TEMP.

2 To change the threshold for Temperature:  
> LOW LIMIT **+** or LOW LIMIT **-**

3 To change the alarm volume, use the ALARM VOLUME controls:

 **+** Increase volume       **-** Decrease volume

4 To turn the alarm off: > OFF.

5 To return to the main screen: > EXIT.

## 9 SonicaidTrend Intrapartum Analysis

### 9.1 Introduction

SonicaidTrend intrapartum analysis is a software option available with all FM800 series monitors. It measures fetal heart rate parameters at regular intervals, and describes the trace in a way that is quantitative and not qualitative. The analysis is not intended as a replacement for skilled visual interpretation of the trace, but it does help you to assess long-term changes in the fetal heart rate pattern.

Caution: the analysis is valid only during the first stage of labour.

No guidelines on interpretation or limits of normality are provided, but the clinician can use the numeric values to identify and quantify the relative changes in fetal heart rate parameters over a period of time.

Numerical description of the trace allows direct comparison between traces. It also provides training support for trace interpretation, and readily available data for clinical research projects.

#### IMPORTANT

SonicaidTrend analysis describes the fetal heart rate on the CTG (NST) record. Interpretation and diagnosis of the record remain the responsibility of the appropriately qualified medical staff.

**Note:** Sonicaid Trend analysis is not approved for sale in the USA and Canada.

## 9.2 SonicaidTrend analysis

Analysis is performed at 15 minutes, and every 15 minutes thereafter. The analysis fits a baseline using the last 60 minutes of fetal heart rate data collected, then calculates the following parameters:

- Baseline heart rate (bpm) for the last 60 minutes
- Baseline heart rate (bpm) for the last 15 minutes
- Short-term variation (msecs) for the last 60 minutes
- Deceleration size (beats) for the last 60 minutes
- Deceleration size (beats) for the last 15 minutes

Note: you can choose to show or hide results for the deceleration size parameter.

### Confidence indicator

The analysis provides a confidence indicator showing the reliability of the baseline fit, and hence the fetal heart rate parameters. Confidence is shown as High, Medium or Low (H, M or L).

If the confidence indicator is Medium or High, the analysis results reliably reflect the fetal heart rate pattern. If the confidence indicator is Low, interpret the results in relation to the appearance of the trace. Use them only if you think they are a sensible reflection of the visually assessed pattern.

### 9.3 Using SonicaidTrend analysis

Turning SonicaidTrend analysis on

By default, SonicaidTrend analysis is turned off.

To turn it on:

- > SETUP
- > INTRAPARTUM ANALYSIS
- > ANALYSIS ON.

Starting SonicaidTrend analysis

- 1 Turn the analysis on.
- 2 Set up FM800 to record a normal CTG (NST).
- 3 Start printing.

Note: when SonicaidTrend analysis is running, the display shows an I in the lower right corner, together with a confidence indicator (see previous page) for each channel.

Stopping SonicaidTrend analysis

Press the printer on/off button to stop the printer.

Deceleration size parameter

To print and display deceleration size:

- > SETUP
- > INTRAPARTUM ANALYSIS
- > DECELERATION PRINTING IS OFF

## 9.4 SonicaidTrend analysis results

### Printed results

The parameter values and confidence indicator are printed on the contractions section of the trace. A key to the parameters is printed on the trace header, and again three minutes before the end of each 60-minute period.

60-minute values are available after the first hour. Until then the results show 'NA'.

### Signal loss

If signal loss is > 50%, the results show 'SL'.

### Displayed results

To display results:

- > SETUP
- > INTRAPARTUM ANALYSIS
- > RESULTS (for ULT1, ULT2 or FECG)

To return to the main screen:

- > EXIT

## 9.5 Viewing trend data

To see a trend of the analysis results for up to the last four hours:

- > SETUP
- > INTRAPARTUM ANALYSIS
- > ULT1 TREND (or ULT2 TREND or FECG TREND)

To return to the main screen:

- > EXIT

## 10 SonicaidCare Antepartum Analysis

### 10.1 Intended use

The intended use of Sonicaid Care analysis is to analyse antepartum CTGs (NSTs) in pregnancies from 26 weeks gestation onwards. It can be used on women who are experiencing Braxton-Hicks contractions, but is not intended for use in established labour as the fetus is then exposed to additional factors such as labour contractions, pharmacological agents, and epidural anaesthesia.

The analysis provided by the Sonicaid Care is intended to assist, not to replace, the physician's visual assessment of a trace. As such, Sonicaid Care is not a diagnosis, but an aid to clinical management. Diagnosis remains the responsibility of an appropriately qualified physician. Indeed, both the physician's visual assessment of the trace and the analysis provided by Sonicaid Care should be considered within the context of a full clinical assessment before decisions are made regarding management. Such a clinical assessment may include further tests such as umbilical blood flow velocity waveforms or biophysical profiling.

**Note:** Sonicaid Care analysis is not approved for sale in the USA and Canada.

### 10.2 Overview

SonicaidCare antepartum analysis is a software option available with all FM800 series monitors. The software tests fetal heart rate parameters against the criteria which define a normal record. Abnormalities are highlighted.

#### IMPORTANT

The analysis describes fetal heart rate, toco and fetal movements. Interpretation and diagnosis of the CTG (NST) record remain the responsibility of the appropriately qualified medical staff.

#### WARNING

The analysis is valid for admission testing, but is not valid during labour.

### 10.3 The Dawes/Redman criteria

- An episode of high variation, above the first centile for gestational age.
- No decelerations > 20 lost beats (> 100 lost beats on records longer than 30 minutes).
- Basal heart rate between 116 and 160 bpm, though a slightly lower or higher rate may be acceptable after 30 minutes, if all other parameters are normal.  
An asterisk on the analysis results shows that the fetal heart rate is low or high, but that in the context of the rest of the record, it is acceptable.
- At least one fetal movement or three accelerations.
- No evidence of a sinusoidal fetal heart rate rhythm.
- Short-term variation should be 3 ms or greater.
- **Either** an acceleration  
**Or** variability in high episodes > the tenth centile **and** fetal movements > 20.
- No errors or decelerations at the end of the record.

### 10.4 Care analysis

Analysis is performed at 10 minutes, and every 2 minutes thereafter up to a maximum of 60 minutes. The analysis fits a baseline to the fetal heart rate data collected so far, and from this measures accelerations and decelerations. Short-term variation is calculated, and episodes of high and low variation looked for.

The system then compares the calculated results with the Dawes/Redman criteria. If the record appears normal, the message CRITERIA MET appears, and FM800 gives a single beep. Otherwise, CRITERIA NOT MET is shown.

You can stop the analysis once the criteria have been met. FM800 produces a report of the analysis results at the end of the trace. Abnormalities are highlighted. If you do not stop the analysis, it is possible for the results to change to CRITERIA NOT MET. As more data is received, a subsequent analysis may re-fit the baseline so that, for example, an episode of high variation is no longer above the first centile.

If you stop FM800 before 10 minutes, the first analysis is not performed. After 60 minutes, the analysis stops, even if you continue monitoring. The results printed will be those from the final analysis at 60 minutes.



Event marks for twins

SonicaidCare analysis does not take account of fetal movements when analysing twins.

Alarms

During analysis the Signal Loss alarm is fixed at 30%. In addition, there is a fixed Toco alarm that alerts the user to a constant Toco value for 10 minutes. Once this alarm has been acknowledged, it will not re-alarm during the same analysis.

Fetal ECG

Since the analysis is not valid during labour, it does not run on the FEKG channel.

## 10.5 Using SonicaidCare analysis

Starting SonicaidCare analysis

- 1 Set up FM800 as you would to record a normal CTG (NST).
- 2 Enter the gestational age  
[ > SETUP > ANTEPARTUM ANALYSIS > GESTATION ]  
Or you can enter the gestational age first:  
[ > SETUP > PATIENT DETAILS > GESTATION ]
- 3 Start printing.

Note: when SonicaidCare analysis is running, the display shows an A in the lower right corner, together with the status for each channel being analysed and an elapsed time indicator. Status indicators are:

- ✓ Criteria met
- x Criteria not met
- N Not applicable (ie no results yet)

Checking the progress of SonicaidCare analysis

To check the key results, after the first analysis:

- > SETUP
- > ANTEPARTUM ANALYSIS
- > ULT 1 RESULTS (or ULT2 RESULTS)

FM800 shows the last calculated values for short term variation, number of minutes of high variation and basal heart rate. An asterisk beside a figure indicates an abnormal result.

See Abnormalities, in Section 10.5.

Stopping SonicaidCare analysis

Stop printing. FM800 prints the analysis results.

Turning SonicaidCare analysis off

- > SETUP
- > ANTEPARTUM ANALYSIS
- > ANALYSIS OFF

The analysis also defaults to OFF when FM800 is switched off, then on again.

## 10.6 SonicaidCare analysis report

When the analysis is stopped, the printer produces a report of the analysis results at the end of the trace. The report shows:

- Values for the calculated parameters
- When the Dawes/Redman criteria were first met
- Whether the Dawes/Redman criteria were met at the time the analysis was stopped
- Abnormalities

#### Reasons for not meeting the criteria

If the criteria were not met when the analysis was stopped, the reasons are given as coded numbers alongside the CRITERIA NOT MET message:

Code	Reason
1	Basal heart rate outside normal range
2	Large decelerations
3	No episodes of high variation
4	No movements and fewer than 3 accelerations
5	Baseline fitting is uncertain
6	Short-term variation is less than 3ms
7	Possible error at the end of the record
8	Deceleration at the end of the record
9	High-frequency sinusoidal rhythm
10	Suspected sinusoidal rhythm
11	Long-term variation in high episodes below acceptable level
12	No accelerations

#### Abnormalities

Double asterisks indicate one of the following conditions:

- Fetal heart rate < 116 bpm or > 160 bpm on a record of less than 30 minutes
- Decelerations > 100 lost beats (> 20 lost beats on record of less than 30 minutes)
- No moves and fewer than 3 accelerations
- No episodes of high variation
- Short-term variation < 3ms
- No accelerations **and**
  - either** < 21 movements per hour
  - or** long-term variation in episodes of high variation below the tenth centile
- Long-term variation in episodes of high variation below the first centile

A single asterisk indicates one of the following conditions:

- Short term variation < 4 ms, but  $\geq$  3ms
- Basal heart rate < 116 bpm or > 160 bpm on a record  $\geq$  30 minutes
- Decelerations present, but not meeting the criteria for size or record length

A single asterisk does not necessarily mean that the record cannot pass the criteria. If all other parameters are normal at the 30-minute point, the abnormality could be considered to be within acceptable limits to meet the analysis criteria.

Basal heart rate warnings

A basal heart rate of 115 bpm or lower triggers a printed warning:

WARNING: LOW BASAL FHR  
CHECK THAT FHR DOES NOT CONTINUE TO FALL  
FETAL MOVEMENTS PRESENT? SINUSOIDAL RHYTHM?

## 11 Using FM800 with a PC System

You can connect FM800 to the following PC-based systems:

- Sonicaid FetalCare analysis and replay system
- Sonicaid Axis central review
- Sonicaid System8002 analysis system
- Sonicaid Centrale
- Hewlett Packard/Philips TraceVue central review
- GMT Argus central system (not approved for use with Sonicaid FM800 in the USA or Canada)

### 11.1 Using FM800 with FetalCare or System8002

Connecting FM800 to FetalCare or System8002

- 1 Connect the Sonicaid FetalCare or Sonicaid System8002 connecting lead to the RS232 S8002 connector on the rear of FM800. See Section 1.4.
- 2 Connect the lead to the COM1 port on the rear of the Sonicaid FetalCare PC or the Sonicaid System8002 PC.
- 3 Make sure the FM800 has the Sonicaid interface enabled. See Section 4.6.

Note: for full details of PC connections, and instructions for using the system, see the *Sonicaid FetalCare User Guide* or the *Sonicaid System8002 Operating Handbook*.

Setting up FM800 for use with FetalCare or System8002

- 1 > SETUP > SYSTEM SETTINGS > access code (2755).
- 2 > SERIAL INTERFACE.
- 3 Make sure the RS232 S8002 button says 'Sonicaid'. If it says 'HP', then press it to change to 'Sonicaid'.
- 4 > EXIT.
- 5 Switch off FM800. Wait for about 10 seconds.
- 6 Switch FM800 on again.

## 11.2 Using FM800 with Sonicaid Axis

Connecting FM800 to an Axis central review system

- 1 Connect the Axis RS485 connecting lead to the RS485 connector on the rear of FM800. See Section 1.4.
- 2 Connect the lead to the Axis Bed Box (RS485 wall socket) in the Labour Room.

Note: for full details of PC connections, and instructions for using the Axis system, see the *Sonicaid Axis User Guide* and the *Sonicaid Axis Installation Guide*.

Annotations on Axis

If you connect FM800 to an Axis central review system, any annotations entered will be displayed in the Axis Notepad. See the *Sonicaid Axis User Guide*.

On an Axis system, annotations appear in the Axis Notepad.

*Note: Sonicaid Axis is no longer offered as a supported product.*

## 11.3 Using FM800 with Sonicaid Centrale, Philips TraceVue™ or GMT Argus

Connecting FM800 to Sonicaid Centrale, Philips TraceVue™ or GMT Argus

There are a number of ways in which FM800 may be connected to Sonicaid Centrale or other CMS's like TraceVue or Argus. Some of the combinations are described below but the list is not exhaustive. For other ways of connecting consult the administrator of your central monitoring system.

### 1 Directly - using RS232

Connect an RS232 lead to the RS232 S8002 connector on the rear of FM800. See Section 1.4. Connect the other end of the lead to a spare RS232 input port of the central monitoring system.

### 2 Directly - using RS422

Connect an RS232 to RS422 conversion lead to the RS232 S8002 connector on the rear of FM800. See Section 1.4. Connect the other end of the lead to a spare RS422 input port of the central monitoring system. Note that the plug with the converter inside (the larger plug) must go at the FM800 end.

**3 Indirectly - using RS232 and an RS232 network adaptor**

Connect an RS232 lead to the RS232 S8002 connector on the rear of FM800. See Section 1.4. Connect the other end of the lead to an RS232 input port on the network adaptor box. Make sure the network adaptor box is connected to the local area network. The network adaptor should be powered by a medically approved power supply. If in doubt, consult the administrator of your central review system or your electrical safety department.

**4 Indirectly – using RS232 and a TraceVue computer with the FM800**

Connect an RS232 lead to the RS232 S8002 connector on the rear of FM800. See Section 1.4. Connect the other end of the lead to an RS232 input port on the TraceVue computer. Make sure the TraceVue computer is connected to the local area network. The computer, and all its peripherals, should be powered via a mains isolating transformer. If in doubt, consult the administrator of your central review system or your electrical safety department.

For full details of PC connections, and instructions for using the system, see the documentation supplied with the central review system.

Note: GMT Argus is not approved for use with Sonicaid FM800 in the USA or Canada

Setting up FM800 for use with Sonicaid Centrale, Philips TraceVue™ or GMT Argus

- 1 > SETUP > SYSTEM SETTINGS > access code (2755).
- 2 > SERIAL INTERFACE.
- 3 Make sure the RS232 S8002 button says 'HP'. If 'Sonicaid' is displayed, then press the RS232 S8002 button to change to 'HP'.
- 4 > EXIT.
- 5 Switch off FM800. Wait for about 10 seconds.
- 6 Switch FM800 on again.

If you connect FM800 to a Philips TraceVue™ system, you can annotate the trace on FM800 using the TraceVue™ system. See the documentation supplied with the Philips TraceVue™ system.

Note: Sonicaid Centrale can also support the 'Sonicaid' protocol option.

## 12 Telemetry

Full instructions in the use of the telemetry transmitter and receiver are given in the operator's manual for the telemetry unit.

For the availability of this manual in other languages, consult:

Rimkus Medizintechnik, Feldkirchenerstrasse 6, D-85599 Parsdorf, Germany

**Note:** Rimkus telemetry is not approved for use with Sonicaid FM800 in the USA or Canada.

### 12.1 Connecting the telemetry unit

- 1 Connect one end of the FM800-to-telemetry cable to the telemetry receiver. See the operator's manual for the telemetry unit.
- 2 Connect the other end of the FM800-to-telemetry cable to the Rimkus connector on FM800. See Section 1.4.
- 3 Connect the telemetry receiver to the main power supply. See the operator's manual for the telemetry unit.

### 12.2 Using the telemetry unit

- 1 Connect the telemetry unit to the main power supply, and to FM800. Switch on the telemetry unit.
- 2 Check that the transmitter is fully charged. See the operator's manual for the telemetry unit.
- 3 With the transducers connected to FM800, not to the telemetry transmitter, examine the mother, and establish the best position for the transducers.
- 4 Attach the transducers securely to the mother.
- 5 Disconnect the transducers from FM800, and connect them to the telemetry transmitter. Leave the transmitter in the receiver unit for the time being.
- 6 Explain to the mother that she should take the transmitter with her when she wants to walk around. Demonstrate the Patient Recall signal to her.

See 'Getting Started with the T800' (Appendix 4).



## 13 Troubleshooting

### 13.1 FHR

No FHR signal displayed	Is FM800 switched on? Is the FHR transducer connected?
High % signal loss	Check transducer placement. Is the transducer broken? Consider switching from Ultrasound to FECG.
No FHR trace printed	Have you pressed the Print button? Is there paper in the paper tray? Is the paper tray fully pushed in?
Only one trace (twins) OR Traces superimposed (twins)	Correct 'FHR scale for twins' in Printer setup. See Section 4.3.
No beep when you press a button	Beep may be turned off. Section 2.2.
Alarm not working	Alarm may be turned off. Section 7.4.

### 13.2 Oximetry

No signal appears when you connect the oximetry sensor	Is the oximetry module connected to FM800?
Signal disappears after you have been monitoring for some time	MSpO <sub>2</sub> : Is the oximetry module connected to FM800?

### 13.3 Fetal event marker

No mark appears on the trace when the mother presses the event marker	Is the event marker connected? Note: it is possible to connect the event marker to the temperature socket by mistake.
FM800 does not beep when the mother presses the event marker	Is the event marker connected? Is the beep turned off? Section 7.5.

### 13.4 Maternal blood pressure error codes

<b>Message</b>	<b>Description</b>	<b>User action</b>
ARTEFACT	Irregular pulse or excessive motion.	Make sure patient keeps still during measurement.
AIR LEAK	Reading terminated because target pressure was not reached within 60 seconds.	The cuff is loose or not connected properly. OR The cuff bladder or hose has a leak. OR The hose is not properly connected to FM800.
OVER PRESSURE	Cuff over-pressurised. Measurement terminated automatically.	Make sure the patient does not press the cuff, or bend her arm too much.
MALFUNCTION	No reading reported.	Check cuff and hose, then try another measurement. If the problem persists, note the error message, and contact Huntleigh Healthcare Ltd or their representatives.

### 13.5 Printing

Poor print quality	<ol style="list-style-type: none"> <li>1 Make sure you have the right paper loaded. FM800 uses Sonicaid paper (part number 8400-8003).</li> <li>2 Make sure the paper tray is fully pushed in.</li> <li>3 Try printing again.</li> <li>4 If there is no improvement, clean the print head. See Section 14.4.</li> </ol>
Some NBP measurements are not being printed on the trace	When NBP measurements are taken every 3 minutes, and print speed is set to 1cm/min, there is not room on the paper for every result. Either take measurements every 5 minutes, or increase the print speed.

### 13.6 What to do next?

If you cannot solve a problem using this Troubleshooting guide, please contact your Huntleigh Healthcare Ltd representative. If you do this, they may ask you what software version your FM800 is running.

To find this out:

- > SETUP.
- > SYSTEM SETTINGS.
- > access code (2755).
- > SERVICE CENTRE.
- > PRODUCT INFORMATION.

PRODUCT INFORMATION		EXIT ►
<b>Model</b>	<b>SONICAID FM830</b>	
<b>Serial Number</b>	<b>FM800-10017</b>	
<b>Date of Manufacture</b>	<b>24/06/2000</b>	
<b>Version</b>		
	<b>SH2 (1)</b>	<b>1.7.0</b>
	<b>SH2 (2)</b>	<b>1.7.0</b>
	<b>PIC (1)</b>	<b>1.4</b>
	<b>PIC (2)</b>	<b>1.3</b>
	<b>EPLD</b>	<b>1.0</b>

Make a note of the numbers listed for SH2 (1), SH2 (2), PIC (1), PIC (2) and EPLD.

## 14 Cleaning and Maintenance

**WARNING:** always switch off FM800 and disconnect the AC supply cable and transducers before attempting to carry out any cleaning or maintenance.

### 14.1 The FM800 main unit

#### Cleaning after use

Wipe the instrument case with a cloth dampened in soap or detergent solution to remove aquasonic gel, blood, saline etc. Wipe dry with a clean cloth.

**Caution:** do not use isopropyl alcohol to clean the FM800 main unit.  
Do not expose metal components (eg snap connectors) to chemicals.

#### Sterilising the case

The only method of sterilisation for the FM800 main unit is by using Ethylene Oxide gas (up to 5.5 bar). Low-temperature steam is NOT permissible.

**Note:** sterilisation is not normally required.

### 14.2 Transducers: NBP cuff, maternal oximetry sensor, temperature probe

For cleaning, disinfection, sterilization and maintenance of these transducers, read the instructions supplied by the manufacturer of the transducers.

### 14.3 Transducers and leads: Ultrasound, FECCG, MECCG, internal Toco and external Toco

Cleaning (Ultrasound, FECCG, MECCG, and external Toco transducers)

After use, wipe the ultrasound transducers, event marker, fetal ECG electrode leg plate and IUP extension cable with a cloth dampened in soap or detergent solution to remove aquasonic gel, blood, saline etc. Wipe dry with a clean cloth.

Caution: do not expose metal components (eg snap connectors) to chemicals.

Disinfection (Ultrasound, FECCG, external Toco transducers and all reusable leads)

After use, clean the transducers as described above. Then wipe the transducers and leads with an alcohol solution (70% ethanol or isopropanol) in accordance with instructions provided by the disinfectant manufacturer.

Care of ultrasound transducers

Ultrasound transducers should be kept dry and preferably below 45°C. Gel must be wiped from the ultrasound transducers after use, and before placing on the storage area on the side panel.

## 14.4 User maintenance

The checks below can be performed by any user of the equipment.

### Mechanical inspection

Every three months:

- 1 Inspect the AC supply cable, transducers, and all other assemblies and connectors for loose or broken parts, or any other damage.
- 2 Pay particular attention to the AC supply socket.
- 3 Look carefully for cracks which may allow the ingress of liquids or gels.
- 4 Replace any broken or damaged transducers or cables.
- 5 If there is damage to the main FM800 unit, contact your local Huntleigh Healthcare Ltd representative.

### Cleaning the print head on the printer

- 1 Pull the paper tray out as far as it will go.
- 2 Remove the paper pack.
- 3 Using a lint-free cloth and pure alcohol, wipe along the full width of the print head, which is beneath the plastic edge of the paper compartment.
- 4 Replace the paper tray and paper pack.

### Check NBP cuffs and hose

Once a month:

- 1 Check the NBP hose. Straighten out any kinks and distortions.
- 2 Check the cuff(s) for wear and damage.

### Check oximetry and temperature sensors

Once a month:

Check the oximetry and temperature sensors for any signs of wear or damage.

## 14.5 Technical maintenance

The checks below should be performed by a qualified maintenance engineer in the hospital.

### Fuse check and replacement

Every six months:

- 1 Remove the fuse module using a small screwdriver.
- 2 Raise the small latch and remove the fuse board for access to the fuses.
- 3 Check the AC supply fuses are of the correct value:
  - 1A for  $\geq 200V$  systems
  - 2A for  $< 200V$  systems

### Functional check

Every six months:

- 1 Connect the AC supply, the transducers and the accessories.
- 2 Switch ON.
- 3 Check that FM800 can perform the functions described in this Reference Manual.

### Check oximetry and temperature sensors

Check the sensors every three months:

- > SYSTEM SETTINGS.
- > SERVICE CENTRE.
- > DIAGNOSTICS.

Follow the instructions on screen.

Check NBP pressure

Every twelve months, check NBP pressure:

> SYSTEM SETTINGS.

> SERVICE CENTRE.

> DIAGNOSTICS.

> NBP CALIBRATION.

Follow the instructions on screen

Note: for calibration to be effective, you need to remove the link on J6 on the NBP module. This involves removing the equipment cover and then the module. Replace the link on J6 after calibration.

## 14.6 Corrective maintenance

All corrective maintenance must be performed by qualified engineers approved by Huntleigh Healthcare Ltd, Sonicaid Products.

The *Sonicaid FM800 Service Manual* (order part number 329801) is designed as an aid to engineers in maintenance and service of repairable parts.

## 14.7 Servicing

Servicing

Servicing should be performed only by Huntleigh Healthcare Ltd or their appointed service agent. If you have difficulty obtaining service for FM800, contact Huntleigh Healthcare Ltd.



## 14.8 Accessories, consumables and spares

### Accessories

FM800 trolley	320501
Intran IUP catheter interconnection lead	8400-6937
Maternal ECG lead	8402-6969
FM800-to-System 8002 lead	8400-6952
Service Manual	329100

### Consumables

#### Aquasonic gel:

20gm sterile sachet	1300-0145
60gm tube	1300-0152
0.25 litre bottle	1300-0153
5 litre container	1300-0154
Membrane for Toco transducer (50)	1300-0216
Transducer belts 1.5 m (pack of 2)	8400-8026
Transducer belt buckle	8400-6208
Sonicaid fetal ECG scalp electrode, spiral (Box of 50)	1400-0160
Belt for Sonicaid fetal ECG electrode leg plate	7481-6101
Safelinc™ fetal ECG scalp electrode (FDA-compliant) (Box of 50)	900X259
Safelinc™ fetal ECG leg plate attachment pad (Box of 50)	900X260
Intran disposable IUP catheter transducer (Box of 10)	8400-8011
Printer paper, 45m.	8400-8003
Adult ECG electrodes, pack of 25	ED-25
Adult ECG electrodes, pack of 50	ED-50

*Sonicaid FM800 Series Reference Manual*

Spares

1.5 MHz ultrasound transducer (yellow)	8400-6919
2.0 MHz ultrasound transducer (blue)	8400-6920
Temperature sensor	320504
Maternal SpO <sub>2</sub> transducer/lead assy	739088
NBP cuff (large adult)	322806
NBP cuff (small adult)	322804
External Toco transducer	8400-6921
Sonicaid fetal ECG electrode leg plate	8400-6922
Safelinc™ fetal ECG connector lead	017D065
Event marker lead	7775-6901
Fuse 2A (100-120V supply)	FUSE22
Fuse 1A (200-240V supply)	1000-0247

\*contact Huntleigh Sales Dept.

## 15 Specifications

### 15.1 Physical and environmental

#### Physical

Height (all models)	186mm (7.3in)
Length (all models)	358mm (14.1in)
Width (FM820)	363mm (14.3in)
Width (FM830)	392mm (15.5in)
Weight (FM820)	Gross weight 18kg (includes transducers etc) Net weight 15kg
Weight (FM830)	Gross weight 19kg (includes transducers etc) Net weight 16kg

#### Recommended operating, storage and transport conditions

Operating temperature	+10°C to +35°C
Storage/transport temperature	-20°C to +50°C
Operating pressure	68 to 106 kPa (680 to 1060 mB)
Storage/transport pressure	68 to 106 kPa (680 to 1060 mB)
Operating humidity	10% to 75% RH, non-condensing
Storage/transport humidity	10% to 90% RH, non-condensing

### 15.2 AC supply voltage and fuse values

Rated AC supply voltage	100–120V, 220–240V, 50–60Hz
Fuse values	T1A L 250V for nominal input voltage ≥ 200V T2A L 250V for nominal input voltage < 200V
Power rating	100VA

### 15.3 Transducers

#### Ultrasound

Range	30 to 240 bpm
Accuracy	± 1 bpm over the range 100-180 bpm
Alarms	High and Low FHR: 30 to 240 bpm Signal Loss: % loss in last 5 minutes
Mode	Directional pulsed Doppler Repetition rate 3.0KHz
Frequency	1.5MHz (yellow) 2.0MHz (blue)
P-	<1Mpa
Iob	<20mW/cm <sup>2</sup>
Ispta	<100mW/cm <sup>2</sup>
Resolution	12 bits
Safety	Type CF protection

#### FECG

Range	30 to 240 bpm
Accuracy	± 1 bpm over the range 100–180 bpm
Alarms	As Ultrasound
Common mode rejection	Better than 66db within the signal bandwidth
Input impedance	10M Ohm
Input range	>30µV to >500µV peak to peak
DC offset	±2V common mode ±300mV differential
Common mode range	±20V @ mains frequency
Noise	<10µV peak-to-peak referred to input
Safety	Type CF protection

Uterine activity (external Toco)

Range	0–100 relative units
Sensitivity	100% FSD equivalent to 120g
Offset range	±100g
Auto zero	Manual and auto zero facility
Safety	Type CF protection

Uterine activity (internal IUP)

Transducers	Intran Plus (or any pre-calibrated transducer)
Pressure range	0–100 mmHg/1–15 kPa (user selectable)
Sensitivity	5 $\mu$ V/V/mmHg
Accuracy	±5%
Safety	Type CF protection

Maternal heart rate and ECG

Range	30–240 bpm
Accuracy	±1 bpm
Alarms:	
High and Low Rate	30–240 bpm
Signal Loss	
Safety	Type CF protection

*Sonicaid FM800 Series Reference Manual*

Maternal blood pressure	
Method	Oscillometric
Measurement ranges	Systolic 50–280 mmHg Diastolic 10–260 mmHg Pulse 40–240 bpm
Accuracy	±2% or 3mmHg, whichever is greater
Modes	Manual or automatic User-selectable interval in Auto Mode: 3, 5, 10, 15, 20, 30, 45, 60, 90 or 120 minutes
Record/display	On-screen display and printed record of: <ul style="list-style-type: none"><li>• Systolic blood pressure</li><li>• Diastolic blood pressure</li><li>• Pulse rate</li></ul> Printed record of: <ul style="list-style-type: none"><li>• Mean arterial pressure</li></ul>
[Note: Mean arterial pressure not shown in the USA or Canada]	
Alarms	Systolic High: 55–255 mmHg Systolic Low: 50–250 mmHg Diastolic High: 35–220 mmHg Diastolic Low: 30–215 mmHg System: air leaks, movement, overpressure etc
Safety	Type CF protection Hardware and software controls to limit: <ul style="list-style-type: none"><li>• Inflation (max. 300 mmHg)</li><li>• Measurement time (max. 160 secs)</li></ul>
Standards	ANSI/AAMI SP10-1992

Maternal oximetry

Sensor types (a)

The following Nellcor™ probes are suitable for FM830 models equipped with Nellcor™ MSpO<sub>2</sub> modules:

Oxisensor® II D-25/D-25L

Oxcliq® A

Durasensor® DS-100A

Dura-Y® D-YS

Do not use any sensors other than these.

(b)

The following BCI probes are suitable for use with FM830 models equipped with BCI (Smith Industry), maternal pulse oximetry technology:

3444 Finger Sensor

WARNING

Do not use the oximetry sensors during magnetic resonance imaging (MRI) scanning. Induced current could cause burns. The oximeter may affect the MRI image, and the MRI unit may affect the accuracy of oximetry measurements.

Saturation range	1–100% SpO <sub>2</sub>
Saturation accuracy	±1SD of normal distribution, within ranges: 70–100% ±2 digits 50–69% ±3 digits 0–49% unspecified
Pulse rate range	20–250 bpm
Pulse rate accuracy	±3 bpm
Record/display	On-screen display and printed record of: Maternal % SpO <sub>2</sub> Heart rate
Alarms	High and low saturation: 0–100% SpO <sub>2</sub> Signal loss: Pulse or ECG

Maternal temperature

Measurement ranges	32–42°C (90–104°F)
Accuracy	±0.2°C between 32 and 40°C
Sensor types	YSI 400 Series Do not use any sensor other than this.

## 15.4 Controls

Simple functions

Control keys on front panel:

- Power on/off
- Volume up/down
- Audio channel select
- Toco/IUP zero
- Printer on/off
- Printer fast forward
- Clinical event mark

Higher-level functions

10 'soft keys' on the display

## 15.5 Printer

Print head

128mm thick film

Resolution

8 dots per mm

Printer speeds

1, 2, or 3cm per minute (user selectable)

10 cm per minute fast forward

Paper

Plain thermal paper, z-fold, 45m length

FHR scales

30–240 bpm or 50–210 bpm (user selectable)

Annotation

- Hospital name, time, date, paper speed, monitoring modes, signal loss
- Mothers name and ID number (optional)



## 15.6 Connections

### Front panel

ULT1 (all models)	1.5MHz ultrasound transducer
ULT2/FECG (all models)	2.0MHz ultrasound transducer/fetal ECG lead
/MECG (all models)	Maternal ECG lead
TOCO/IUP (all models)	Toco transducer/IUP lead
MSpO <sub>2</sub> (FM830)	Maternal pulse oximetry
NBP (FM830)	Maternal non-invasive blood pressure
MTEMP (FM830)	Maternal temperature

### Rear panel, all models

RS232	4, isolated (NB the RS232 S8002 connector will also accept an RS232 to RS422 adaptor lead for connection to Philips TraceVue™)
RS485	1, isolated (not used)
Auxiliary	1, for telemetry system
VGA	1

### Interfaces

Telemetry	Rimkus Telemetry
System	Sonicaid Centrale Sonicaid Fetalcare Sonicaid Axis central review Sonicaid System 8002 FHR analysis Philips TraceVue™ central review system GMT Argus central review system*
External maternal monitors	Not available

\* GMT Argus is not approved for use with Sonicaid FM800 in the USA or Canada.

## 15.7 Display

Technology	Electroluminescent
Size	11.5cm x 8.6cm (4.5in x 3.4in)
Resolution	¼ VGA, 320 x 240
Viewing Angle	>160° You can also run FM800 with a VGA monitor connected, for training purposes. See note on page 9 before connecting.
Data display	
ULT1 and ULT2	Fetal heart rate (30–240 bpm) Pulse rate lamp and confidence indicator
FECG	Fetal heart rate (30–240 bpm) Pulse rate lamp
MECG	Maternal heart rate (30–240 bpm) Pulse rate lamp
TOCO	0–100 (relative units)
IUP	0–100mmHg or 1–15 kPa
MSpO <sub>2</sub>	Oxygen saturation Pulse amplitude Pulse rate
NBP	Systolic and diastolic pressures Pulse rate
MTEMP	Temperature, °C or °F

## 15.8 Safety

- i) FM800 is designed to comply with:  
EN60601-1 (1990)
- ii) FM800 is Class 1 equipment, with protective earth via the AC mains input. FM800 must be connected to an earth supply complying with local safety standards. The installation engineer must check the correctness of the supply voltage label and the fuse ratings for the local supply.
- iii) This equipment is not explosion-proof and must not be used in the presence of flammable anaesthetics. It is ordinary equipment (not drip-proof or splash-proof), designed for continuous operation.
- iv) The equipment must be serviced only by authorised and qualified personnel. Huntleigh Healthcare Ltd cannot accept responsibility for safety compliance, reliability and performance if modifications or repairs are carried out by unauthorised personnel. Identical replacement parts must be used.
- v) If there is doubt whether FM800 is operating correctly, when being used on a patient, fetal condition must be checked by an alternative diagnostic method without delay.
- vi) The protective category against electric shock of all patient-applied parts is Type CF. 
- vii) Installation is the responsibility of the vendor via a competent person, approved by Huntleigh Healthcare Ltd.
- viii) This equipment is not protected against:
  - a) the effects of defibrillator shocks or discharge.
  - b) the effects of high-frequency currents.
  - c) the effects of 'bistoury', either TENS (Transcutaneous Electrical Nerve Stimulation) or electro-surgery.

ix) The nature of the parts in direct or indirect contact with the patient is:

Ultrasound transducers	ABS plastic
External Toco transducer	Medical grade polyacetyl
Sonicaid FECG electrode	Stainless steel
Sonicaid FECG electrode lead	Stainless steel, rubber
Safelinc FECG electrode	Stainless steel
Intran IUP catheter	Polyurethane plastic
Temperature probe	Stainless steel
MSpO <sub>2</sub> probe	Biocompatible plastics
Transducer belts	Latex-free fabric
ECG leg plate belt	Fabric

## 15.9 Ultrasound safety considerations

### General

Diagnostic ultrasound has been in use for over 35 years with no confirmed adverse effects on patients or instrument operators at the intensities typical of present diagnostic instruments. However, available data are not wholly conclusive, and the possibility remains that biological effects may be identified in the future.

It is therefore deemed desirable by medical and scientific authorities that exposure to ultrasound be limited to the duration and intensity appropriate for the clinical objective. Because fetal tissue could be more sensitive to biological effects by reason of rapid cell division, it is particularly desirable that ultrasound exposure of pregnant subjects be kept to a minimum.

At present, there is a clear consensus that the benefits to patients of prudent use of diagnostic ultrasound outweigh the risks, if any, that may be present. See:

- a) Report No. 24, National Council on Radiation and Protection: biological effects of ultrasound, clinical effects and observations.
- b) Ziskin M.C., in World Policies on the Use of Diagnostic Ultrasound in Obstetrics: The American Institute of Ultrasound Policy and Statement on Safety. Ultrasound in Medicine and Biology 12: 711-714, 1986.

#### Fetal use

FM800 is designed for continuous fetal heart rate monitoring during pregnancy and labour. Interpretation of fetal heart rate patterns can diagnose fetal and maternal problems and complications.

#### Minimising patient exposure

The acoustic output of FM800 is internally controlled and cannot be varied by the operator. The duration of exposure, however, is fully under his or her control. The examination techniques we have recommended will help the user to get the maximum amount of diagnostic information with the minimum amount of exposure.

#### Acoustic output

Sonicaid FM800 is exempt from the declaration of acoustic output information in accordance with clause 4 of IEC 1157 (EN 61157). This is because the maximum probable levels of the following three parameters are below the limits specified in clause 6, namely:

peak negative pressure	< 1MPa
output beam intensity	< 20mW/cm <sup>2</sup>
spatial-peak temporal-average intensity	< 100mW/cm <sup>2</sup>

Power measurements were made by the National Physical Laboratory, Teddington, Middlesex, UK in accordance with NEMA UD-2 (1998)

## 16 Appendix 1: Service and Warranty

Huntleigh Healthcare Ltd (HHC.) provides a comprehensive warranty of 2 years from the date of purchase on hardware products and modules. Transducers have a 12-month warranty, and consumables and accessories (ie disposables and items with no serial number) have a 90-day warranty.

The warranty covers parts and labour necessary to rectify any faults in the product hardware. If within the warranty period any of the goods supplied prove defective due to faulty design, workmanship or materials HHC. will adjust, repair or replace them free of charge, as follows:

- Monitors will be repaired or replaced at the discretion of HHC.
- Defective consumables will be replaced.

Any problems should be reported immediately to the supplier of the equipment or your local HHC. service department.

The warranty is valid in all circumstances provided that:

- a) the goods have been used in accordance with the operating instructions, and solely for the purpose for which they were intended;
- b) the defect has not been caused by misuse or accident, unauthorised alteration, repair or maintenance, or the use of sub-standard consumables;
- c) kit products have been fitted in accordance with the installation instructions;
- d) repair of the goods has not been attempted by a person or company which is not an approved Huntleigh Healthcare Ltd representative;
- e) the purchaser shall be liable for any costs incurred by HHC. or its appointed agent in responding to claims caused by operator error or incorrect application.

## 17 Appendix 2: External Connections

### A2.1 Input/output levels and pin numbers

RS485 interface

Pluggable cord connector (PCC), isolated to 1.5kV DC. (No longer used).

Interface for Sonicaid Axis. (Now Obsolete).

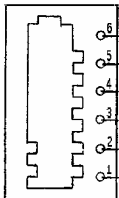
	Pin	Signal	Input/Output
	6	0V reference	
	5	Tx	Input/Output
	4	Not connected	
	3	Bed resistor	Input
	2	Rx	Input
	1	Bed resistor	Input/Output

RS232 interface: RS232 S8002

9-way D-type socket, isolated to 500V DC.

Isolated interface to a PC running System 8002, FetalCare; etc.

From units at modification state 4 or greater, isolated, current-limited supplies of  $\pm 10$  volts are available to power an RS232 to RS422 converter.

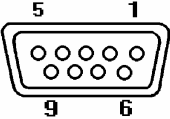
	Pin	Signal	Input/output
	1	Isolated -10V	Output, power 232 to 422 converter
	2	Rx	Input
	3	Tx	Output
	4		
	5	Isolated 0V	Reference
	6		
	7		
	8	Isolated +10V	Output, power 232 to 422 converter
	9		

RS232 interface: all other RS232 connectors

[NB the firmware to support these RS232 sockets is not yet implemented)

9-way D-type socket, isolated to 500V DC.

Isolated interface to other monitoring equipment.

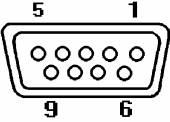
	Pin	Signal	Input/output
	1		
	2	Rx	Input
	3	Tx	Output
	4		
	5	Isolated 0V	Reference
	6		
	7		
	8		
	9		

Fetal event marker connector

1/4" jack socket.

Pin	Signal
1 Tip	Switch
2 Ring	Signal ground (via switch)
3 Sleeve	Chassis ground, via anti-static network



## 18 Appendix 3: Transducer Problems

The following tests will show whether there is a problem with an Ultrasound transducer. If there is a problem, contact the Service Department of Huntleigh Healthcare Ltd, or their appointed service agent.

### Preliminary

- 1 Connect the ultrasound transducer to FM800.
- 2 Turn on FM800.
- 3 Select the required audio channel.
- 4 Adjust the volume to the required level.

### System test

- 1 Hold the ultrasound transducer in one hand, with the transducer face against the palm.
- 2 Stroke the back of the hand repeatedly with one finger. See diagrams below.  
If necessary, use water or gel to obtain good contact between the palm and transducer.
- 3 Check that the audio output, pulse lamp, heart rate display and printer trace on FM800 are synchronised with the finger movement.

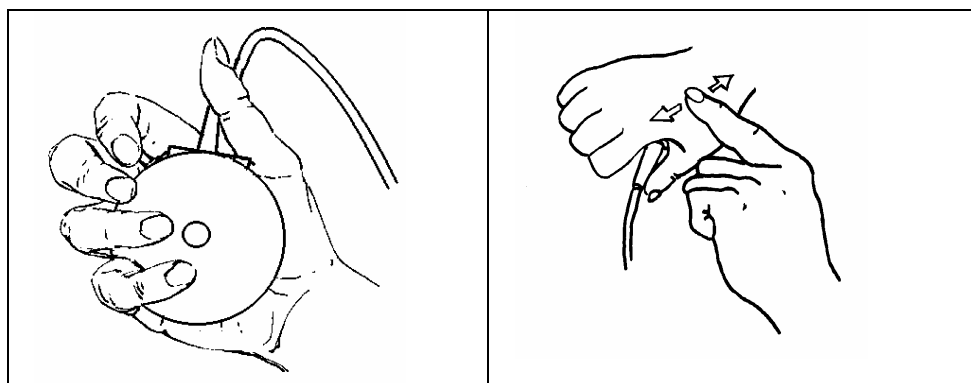

#### Ultrasound transducer test

The crystal elements in a transducer can be damaged if the transducer is dropped. If one or more crystals have been damaged, this can leave non-receptive areas on the transducer face, reducing the beam coverage.

The positions of the crystals behind the transducer face are shown below:

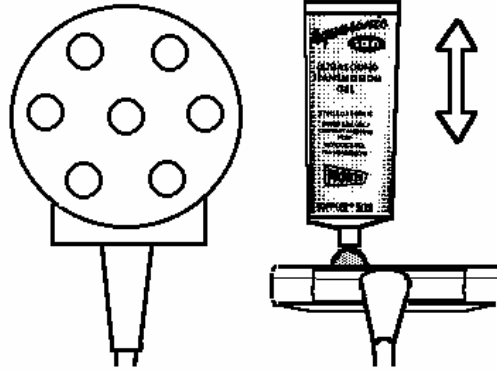

- 1 Squeeze a small amount of Aquasonic gel on to the transducer face over each crystal.
- 2 Move the gel tube rapidly up and down over each crystal, keeping the tip of the gel tube in contact with the transducer. Check that you get an audio signal synchronised with the tube movement.

## 19 Appendix 4: Getting Started with T800



### Connecting the T800 Wireless Transducer System

1. Ensure the receiver aerial is fitted and securely fastened to the connector on the rear panel.
2. Connect the power cable from a suitable wall socket to the mains connector on the rear panel.
3. Plug the end of the data cable labelled T800E into the 15way 'D' socket on the rear panel.
4. Plug the other end of the cable labelled FM800 into the 15way 'D' socket on the rear panel of the FM800.
5. Before operating, ensure the transducers are plugged in and fully charged (takes 3 to 4 hours).

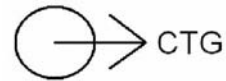

Battery Charging (Amber)





Battery Fully Charged (Green)

### Monitoring FHR and Uterine Activity

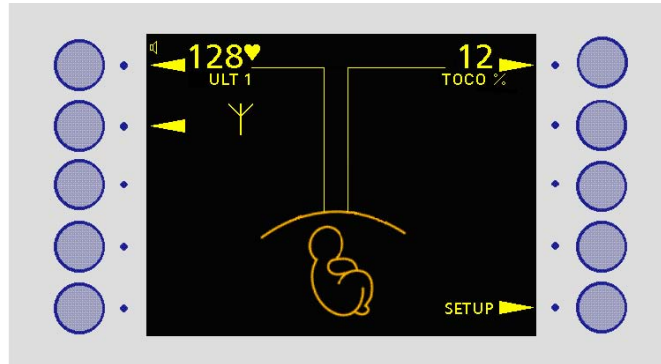





1. Unplug the T800 transducers. The FM800 display will indicate 'Wireless Transducers' in use.

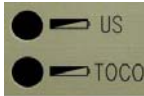

2. To monitor the FHR, determine fetal lie and position. Apply gel to the blue transducer face. Position on the abdomen so as to get optimal fetal heart sounds. Secure in position with belt.
3. Make sure FHR is clear, and distinct from the maternal pulse taken from the patient's wrist. FHR signal quality is shown by the flashing heart symbol.
4. Adjust the volume of the fetal heart sounds to your desired level. 
5. To monitor uterine activity, position the grey Toco transducer halfway between the fundus and the umbilicus, and secure with belt.
6. Zero the Toco. Make sure the uterus is relaxed, then press the pink Toco zero button. 

Monitoring FHR and Uterine Activity

During use, the T800 displays the transducer battery life and RF signal quality as indicated below.

Transmitter off or out of range (Black)	
Ultrasound and Toco transducer battery state – GOOD (Green)	
Ultrasound and Toco transducer battery state – LOW (Amber)	
Ultrasound and Toco transducer battery state – EMPTY (Red)	
Transducer battery low or out of range (Red)	
Transducers in range (Green)	
Weak RF signal (Amber)	

On completion or monitoring session

1. Clean the transducers and return them to the T800 by plugging them into the front panel for charging.
2. Return the FM800 to normal 'wired' transducer monitoring by pressing the button adjacent to the X?

